

JUSTIFICATION OF THE CULTIVATOR SWEEP AND STRENGTHENING ELEMENTS ON THE WORKING SURFACE

ОБГРУНТУВАННЯ ПАРАМЕТРІВ КУЛЬТИВАТОРНОЇ ЛАПИ ТА ЕЛЕМЕНТІВ ЗМІЦНЕННЯ ЇЇ НА РОБОЧІЙ ПОВЕРХНІ

Prof. Ph.D. Eng. Kobets A.S., Lect. Ph.D. Eng., Pugach A.M., Prof. Ph.D. Agri.Sci. Kharytonov M.M.
Dnipro State Agrarian and Economics University, Faculty of Agrarian Engineering / Ukraine;
Tel: 0973456227; E-mail: envteam@ukr.net, S.Yefremova st. 25, Dnipro, Ukraine

Keywords: cultivator, sweep, strengthening elements, working surface, geometric model, substantiated parameters

ABSTRACT

A geometric model and substantiated parameters of the surface of the cultivator sweep, equipped with local strengthening elements have been developed. The minimum inclination angle of the guide is 27° , which was taken into account when designing the sweep construction. The method of designing the cultivator sweep surface, including the formation of the guide curve, the construction of the frame surface, the determination of horizontal, frontal, profile sections and the construction of the scan, was developed. The limits for changing the cultivator sweep parameters with local reinforcement elements are determined.

РЕЗЮМЕ

Обгрунтовані геометрична модель і параметри поверхні культиваторної лапи, оснащеної елементами локального зміцнення. Мінімальним кутом нахилу напрямної є кут 27° , котрий слід приймати при розробці конструкції лапи. Розроблено методику проектування поверхні культиваторної лапи, що включає формування направляючої кривої, побудова каркасу поверхні, визначення горизонтальних, фронтальних, профільних перерізів і побудову розгортки. Встановлено наступні межі зміни параметрів культиваторної лапи з локальними елементами зміцнення.

INTRODUCTION

More than 60% of the Ukraine soils are deep, fertile chernozems (black soil) and more than 75% of them is under cultivation (Slowinska-Jurkiewicz et al, 2013). Tillage tools apply direct energy to the black soil in order to obtain some desired effect such as cutting, breaking, inversion or movement of soil (Biswas, H.S., 1993). Seedbed preparation greatly contributes to the overall cost of farm operations, implying that significant savings are possible through optimized design and development of tillage machinery (Shinde et al., 2011). Modern trends in obtaining environmentally safe products require at least partial refusal of chemical weed control (Dewangan and Rajput, 2017; Vasylieva, 2017; Vasylieva and Velychko, 2017). It is recognized that the use of cultivators is the most effective engineering tool for weed control (Hanna et al., 2000; Sullivan, 2003). There are basically three types of cultivators: field cultivators, row crop cultivators, and rotary cultivators (Srivastava et al., 2008). Consequently, nowadays, requirements for the technical level of cultivators are increasing. It is necessary to emphasize that the soil tillage is a process with high – energy consumption (Gheres, 2014). The objective of mechanical manipulation of the soil designed to agricultural production is to create favourable soil conditions and the environment for crop growth by changing bulk density, soil granulometry size distribution and other characteristics (Ivan and Deac, 2007; Rusu et al., 2013).

The analysis of cultivators' recent developments determines the following main areas of their improvement:

- optimization of the machine overall layout;
- creation of fundamentally new working bodies;
- development of combined assemblies;
- increase of working bodies wear resistance;
- increase of the cultivator sweep cutting capacity;
- improvement of stability process in capture depth and width.

The first three areas require fundamental theoretical and practical research (Kiss and Bellow, 1981; Galat and Ingale, 2016). The remaining approaches are related to solving constructive problems. All methods of extending the cultivator sweeps service life can be divided into two groups. The first group is represented by operational methods including the following ones: sweep restoration by pulling; application of various ways of sharpening the blade (Zhang and Kushwaha, 2004; Wang and He, 2002; Saxena, 2009). The second group is represented by constructive methods: the execution of the sweep of the prefabricated structure, solid alloy blade surfacing, application of local blade strengthening (Badegaonkar et al., 2009), change in the geometry of the sweep surface (Hanna et al, 1993; Gheres M. I., 2014). The geometry of the cutting edge or of the work surface contour of a tool for processing soil shows a particular importance in minimizing the necessary energy for the working process (Tutunaru et al., 2014). The most common way to improve the cultivator wear resistance is for a solid alloy to be applied on the blades. This method of increasing wear resistance has been widely used due to the slight change in the design of cultivator sweeps with a significant increase in service life. It was substantiated that reducing the thickness of the coating and enlargement of the crumbling angle increases the sweeps impact strength (Shafi et al., 2007).

The objective of this study is to develop a geometric model and substantiate the parameters of the cultivator sweep surface equipped with elements of local strengthening.

MATERIALS AND METHODS

The research methodology is based on the shape of the profile, depending on: the direction of the elements orientation and the ratio of high-speed push and static vertical pressure. The main tasks of the study were:

- to obtain the blade profile in the predefined configuration;
- to reveal correlation relations between the profile of the formed teeth and the parameters of the local strengthening strips;
- to study the impact of introduced structural changes on the performance quality in comparison with the standard design cultivator sweep.

Taking into account the cultivator sweep specific operation in the point zone, which occurs along the line curve, on the basis of the deployed surface general model, a surface component has been proposed. Surface parameters are shown in Fig. 1.

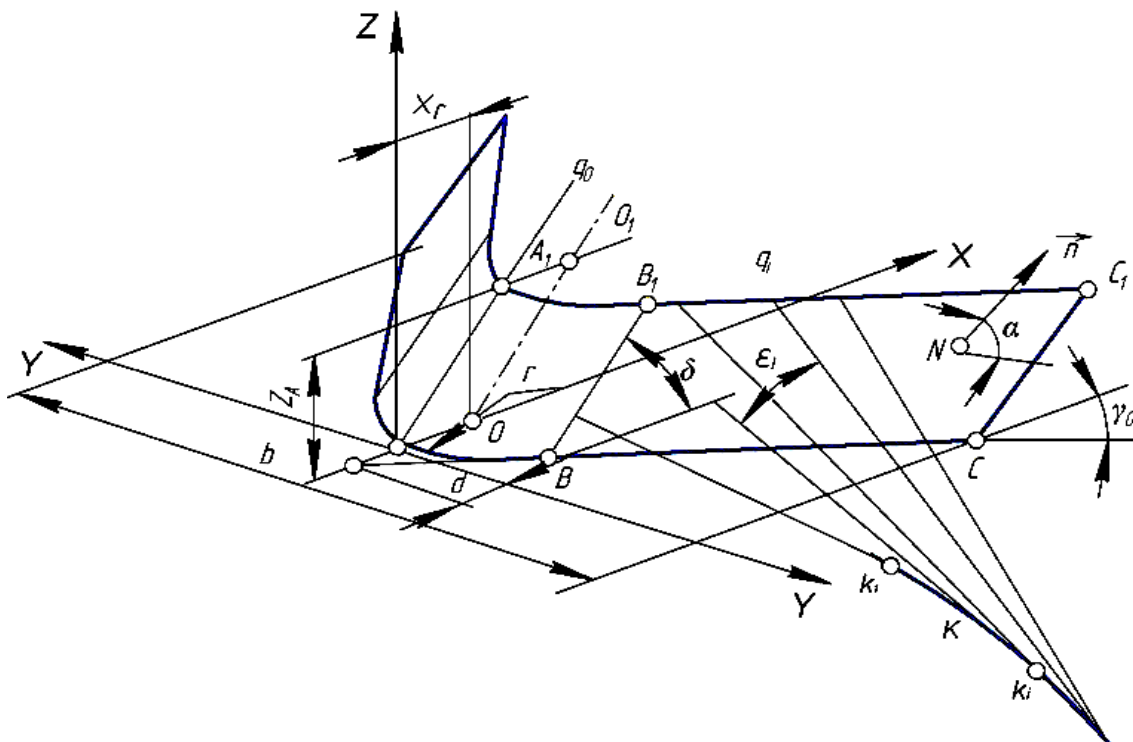

Fig.1 - Scheme of the cultivator sweep surface parameters

(parameter meaning: b - width of sweep grip, mm; Z_a - height of the cultivator sweep surface, mm; k - inclination angle of the generatrix on the projection horizontal plane, mm)

Component of the cultivator sweep surface with local strengthening elements are shown in figure 2.

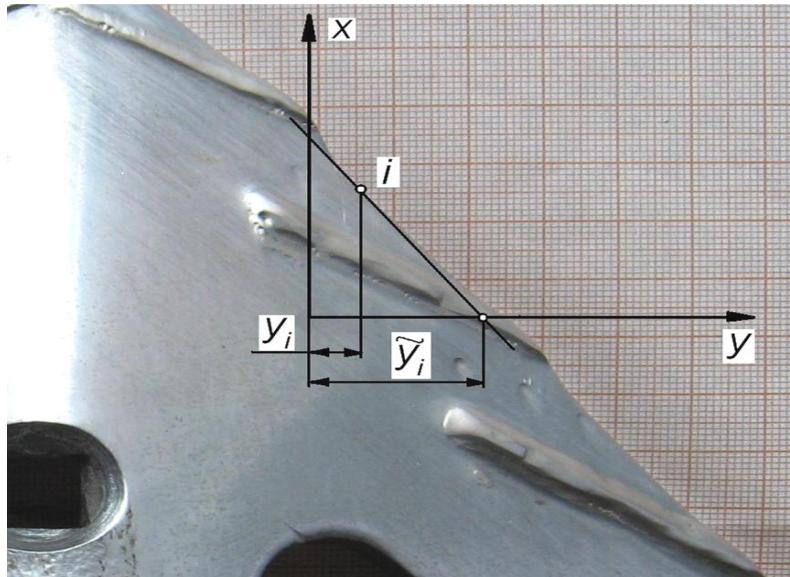

Fig. 2 - Component of the cultivator sweep surface with local strengthening elements

The sweep surface consists of a cylinder surface with an axial line OO_1X and an area BB_1C_1C , which are conjugated to the generatrix of the cylinder BB_1 . The cylinder has a radius r , and the normal \vec{n} area, taken from the point N_o , has a slope to the horizontal area of the projection at an angle α_1 . The angle α_1 is determined by the dependence

$$\alpha_1 = 90^\circ - \alpha \tag{1}$$

where α - the angle of crumbling, degree.

Thus, the scrolling guide surface consists of two lines: the arc of the circle OBB'

$$(x - x_r)^2 + y^2 = r^2 \tag{2}$$

where x_r - the distance from the centre of the circle O_1 to the coordinates; r - the radius of curvature of the sweep point, mm. Straight line BC equation has the form:

$$y = tg\gamma_0 x + d_1 \tag{3}$$

where $d_1 = x_B - y_B \cdot tg\gamma_0$, γ_0 - the angle of guide inclination, degree;

x_B and y_B - coordinates of the point B of a circle transition in a straight line

RESULTS

The coordinates of the transition point B will be determined by differentiating (2) and (3) by x .

$$\frac{dy}{dx} = tg\gamma_0 \quad \text{and} \quad x - r + y \frac{dy}{dx} = 0$$

Substituting in the second equation the expression of the first derivative from the first equation, and taking into account that $x_r = r$, we obtain the first equation for determining the coordinates of the point B

$$x - r + y \cdot tg\gamma_0 = 0 \tag{4}$$

By adding to the equation obtained, the equation of a circle, we obtain a system for determining the coordinates of the point B

$$\left. \begin{aligned} x - r + y \cdot tg \cdot \gamma_0 &= 0 \\ (x - r)^2 + y^2 &= r^2 \end{aligned} \right\} \tag{5}$$

Thus, the guide curve of the cylindrical surface of the sweep point will be the arc of the circle BOB'

$$y = \sqrt{r^2 - (x - r)^2} \tag{6}$$

Generatrix for a cylindrical surface will be a line BB_1 defined by the system:

$$\left. \begin{aligned} z &= tg \delta x + x_\epsilon, \\ y &= \sqrt{r^2 - (x - r)^2} \end{aligned} \right\} \tag{7}$$

We will write the equation of the sweep wings as an equation of an area passing through three points. Two of them are the point of transition of the guiding point of the sweep $B(x_\epsilon, y_\epsilon, z_\epsilon)$ and the point $C(x_c, y_c, z_c)$ - the extreme point of the sweep blade. These points lie in the horizontal area Oxy . The third point N we define as being arbitrary. The area BB_1C_1C , rotating around the straight line BC , may take any position, which will ultimately be determined by the coordinates of the point N . Thus, fixing two points, B and C , and determining the inclination angle α_1 of the normal to the horizontal projection area, we fix the coordinates x_N, y_N and z_N .

The equation of an area passing through three points B, C, N , looks like a determinant:

$$\begin{vmatrix} x - x_\epsilon & y - y_\epsilon & z - z_\epsilon, \\ x_c - x_\epsilon & y_c - y_\epsilon & z_c - z_\epsilon, \\ x_N - x_\epsilon & y_N - y_\epsilon & z_N - z_\epsilon \end{vmatrix} = 0.$$

Let's expose it to minors and algebraic supplements:

$$\begin{aligned} (x - x_\epsilon) \begin{vmatrix} y_c - y_\epsilon & z_c - z_\epsilon \\ y_N - y_\epsilon & z_N - z_\epsilon \end{vmatrix} - (y - y_\epsilon) \begin{vmatrix} x_c - x_\epsilon & z_c - z_\epsilon \\ x_N - x_\epsilon & z_N - z_\epsilon \end{vmatrix} + \\ + (z - z_\epsilon) \begin{vmatrix} x_c - x_\epsilon & y_c - y_\epsilon \\ x_N - x_\epsilon & y_N - y_\epsilon \end{vmatrix} = 0. \end{aligned}$$

Applying the abbreviated notation for minors, we obtain the area equation from the general form:

$$A_x + B_y + C_z + D = 0 \tag{8}$$

$$\text{where } A = \begin{vmatrix} y_c - y_\epsilon & z_c - z_\epsilon \\ y_N - y_\epsilon & z_N - z_\epsilon \end{vmatrix}; B = \begin{vmatrix} x_c - x_\epsilon & z_c - z_\epsilon \\ x_N - x_\epsilon & z_N - z_\epsilon \end{vmatrix}; C = \begin{vmatrix} x_c - x_\epsilon & y_c - y_\epsilon \\ x_N - x_\epsilon & y_N - y_\epsilon \end{vmatrix}.$$

$$D = B_{y_\epsilon} - A_{x_\epsilon} - C_{z_\epsilon}.$$

where D - the power of the dynamic pressure, N.

The inclination angle of the normal \vec{n} to the bottom of the furrow is $\alpha_1 = 90^\circ - \alpha$,

where α - the inclination angle of the area BB_1C_1C , which is the angle of crumbling.

The angle between two areas α is determined by the dependence

$$\cos \alpha_1 = \frac{AA_2 + BB_2 + CC_2}{\sqrt{(A^2 + B_1^2 + C^2) \cdot (A_2^2 + B_2^2 + C_2^2)}}, \tag{9}$$

where A, B, C - coefficients of the sweep area equation;

A_2, B_2, C_2 - coefficients of another area

Imagine one of the areas as a horizontal area of the furrow bottom. Then, its equation will take the form:

$$C_2 z = 0. \tag{10}$$

Since the area (10) is horizontal, equation (9) will take the form:

$$\cos \alpha_1 = \frac{C}{\sqrt{A^2 + B^2 + C^2}} \tag{11}$$

In order to get rid of the radical in the denominator, we bring the resulting expression to the square:

$$\cos^2 \alpha_1 = \frac{C^2}{A^2 + B^2 + C^2}$$

Taking into account (8), the expression can be written in the form:

$$\cos^2 \alpha_1 = \frac{C^2}{\begin{vmatrix} y_c - y_e & z_c - z_e \\ y_N - y_e & z_N - z_e \end{vmatrix}^2 + \begin{vmatrix} x_c - x_e & z_c - z_e \\ x_N - x_e & z_N - z_e \end{vmatrix}^2 + C_1^2}$$

Since y_N and x_N can be any positive numbers, then ticking

$$y_c - y_e = R, \quad z_c - z_e = T, \quad y_N - y_e = K, \quad x_c - x_e = E, \quad x_N - x_e = F,$$

it is possible to solve the expression regarding z_N . So, we give the resulting expression in the form:

$$\begin{vmatrix} R & T \\ K & z \end{vmatrix}^2 + \begin{vmatrix} E & T \\ F & z \end{vmatrix}^2 + C^2 = \frac{C^2}{\cos^2 \alpha}$$

where $z = z_N - z_a$.

Conducting transformations, we come to a quadratic equation:

$$az^2 - 2bz + C^2 \left(1 - \frac{1}{\cos^2 \alpha}\right) = 0 \tag{12}$$

where $a = R^2 + E^2; \quad b = T(R \cdot K + E \cdot F)$

As a result of the corresponding transformations, the coordinate z_N will be equal to:

$$z_N = z_a \pm z_{1,2}, \tag{13}$$

where z_1 and z_2 - the roots of the quadratic equation (13).

Forming g , by which the local elements of the strengthening will be located, are determined by the system and simultaneously lie in the area BB_1C_1C . This position imposes to the parameters $k, l, mk, ml + n$, the corresponding connection. To identify the nature of this connection we substitute the equation of the coordinate area y, z , in the expression from the equation of the straight line.

$$A_x + B \cdot (kx + l) + C(mkx + ml + n) + D = 0$$

With known values of the area coefficients A, B, C , which are determined by the coordinates of the points B, C, N we obtain the equation for one of the line parameters as a function of the coordinate x , for example, regarding the angular coefficient k

$$k = -\frac{Ax - B \cdot l - C \cdot m \cdot l - l \cdot n - D}{(B + C \cdot m)}$$

Each generatrix g is tangent to the curve R , which is the edge of the unfolding surface return and has an angle of inclination to the horizontal area ε .

The equation of the return rib is determined by a system of equations:

$$\left. \begin{aligned}
 x_R &= -\frac{m'l + m'l + n'}{m'k + mk'} \\
 R: y_R &= kx + l, \\
 z_R &= mkx + ml + n.
 \end{aligned} \right\}$$

After removing the dependence of the parameter k from x $k = k(x)$ it is necessary to take the next step. It is essential to determine whether the coordinates of the return ribs fall into an area limited by the wing area BB_1C_1C . If this condition is not met, you need to change one of the functions m , l or n and repeat the calculation. The straight-line guide, which is the initial form of the blade, is located at an angle to the direction γ_i of the cultivator sweep movement. In the process of work, due to the presence of local strengthening elements, some teeth having a profile KE can be formed on the blade, as shown in Fig. 3.

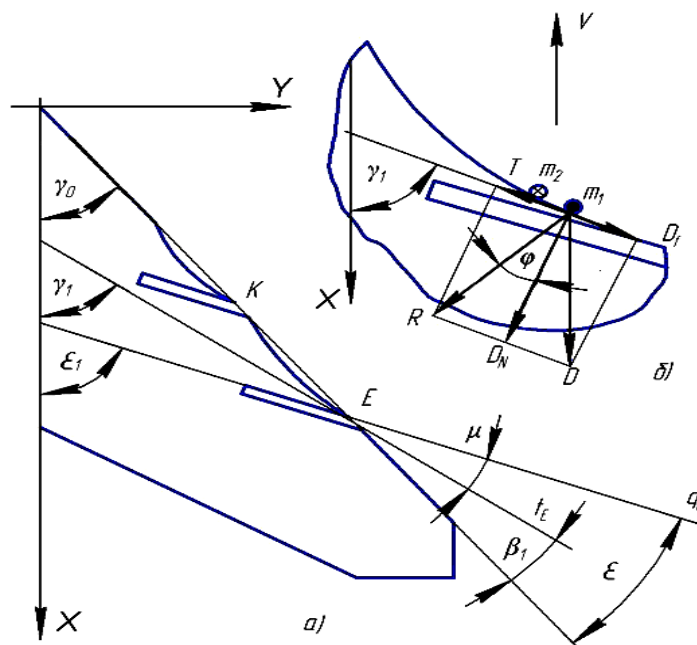

Fig. 3 - Scheme of guide inclination angle substantiation
a - angular parameters of the strengthening elements and the tooth;
b - the forces influencing the particles when moving on the tooth profile

As a result of the sweep operation, the curvature increases, therefore, with the increase in working time, the inclination angle of the tangent γ_1 at the point E will increase and in the limiting sense, it will become equal to the angle of the establishment of the local reinforcement element $\gamma_1 = \epsilon$, where ϵ - inclination angle of the reinforcing element, degree. In accordance with the scheme (fig.3a), we will write the relation of the angles between the tangent to the profile of the blade γ_1 and the establishment of the strengthening element:

$$\mu = \epsilon - \gamma_1 \tag{14}$$

then

$$\gamma_1 = \epsilon - \mu \tag{15}$$

$$\epsilon_2 = \gamma_1 - \mu \tag{16}$$

In its turn, the angle between the generatrix g_E and the guide is equal to:

$$\epsilon_1 = \epsilon - \gamma_0$$

where
$$\gamma_o = \varepsilon - \varepsilon_1 \quad (17)$$

and taking into account (16)

$$\gamma_o = \gamma_1 - \mu - \varepsilon_1 \quad (18)$$

Laboratory and field experiments have determined that the angle β_1 in the established mode is equal to the difference in the angle of the local reinforcement element installation ε_2 with the inclination angle γ_1 of the tangent t_E at the point E , is equal to:

$$\beta_1 = \gamma_1 - \gamma_o = 7^\circ$$

Therefore, in order to substantiate the inclination angle of the guide γ_o , it is necessary first of all to determine a limiting value γ_1 that ensures movement of plant remains, plant roots or soil on the tooth profile. The justification of the angle γ_o must be divided into two stages: a) initial work of the sweep when the tooth is not formed yet. In this case $\beta_1 = 0$ and $\gamma_1 = \gamma_o$. The angle γ_o is chosen from the condition of weeds cutting, thus $\gamma = 90^\circ - \phi_3$, where ϕ_3 - the angle of weed friction by metal, degree; b) the second stage of the work is that the tooth profile begins to form, the tangent at the point E being at an angle γ_1 different from the inclination angle of the guide to the motion direction. As the tooth profile forms, the angle γ_1 increases and reaches in the established mode, the value equal to the angle ε_2 of the determination of the strengthening elements. To determine the limit value of the angle γ_1 , we take the following assumptions: weed or part of the soil is in a homogeneous moving of soil flow, the mass of the weed or a part of the soil is concentrated at the point.

If you move the sweeps in the soil to any part, whether it is plant residue, plant root or soil aggregate, the following forces will act on the sweep profile: force of a dynamic push, N .

$$D = \rho s v^2 \quad (19)$$

which is decomposed into a tangent component

$$D_t = \rho s v^2 \cos^2 \gamma_1, \quad (20)$$

and normal component:

$$D_N = \rho s v^2 \sin^2 \gamma_1,$$

Friction force:
$$T = f \cdot D_N = f \rho s v^2 \sin^2 \gamma_1, \quad (21)$$

where ρ - soil density, kg / m³; s - cross - section of a particle, m²; v - speed of the working body movement, m / s; f - friction coefficient.

The condition of the particle movement on the tooth profile will look as follows, when the force of the tangent component of the dynamic push is higher than the friction T force

$D_t \geq T$, or, having substituted the values of forces, we have:

$$\rho s v^2 \cos^2 \gamma_1 \geq f \rho s v^2 \sin^2 \gamma_1.$$

By reducing on $\rho s v^2$, we get a relation, in which there is only the inclination angle γ_1 and the friction coefficient

$$\cos^2 \gamma_1 \geq f \sin^2 \gamma_1$$

After conversion, we turn to the expression

$$\operatorname{tg} \gamma_1 \leq \sqrt{\frac{1}{f}}. \quad (22)$$

Choosing friction coefficient f is quite important. To make this choice, we consider the motion of two particles m_1 and m_2 on the tooth profile KE in accordance with the scheme (fig. 3, b).

Let the particle m_1 moving in front of the particle m_2 be a vegetative remain or the plant root with a friction angle on the steel φ_3 and, accordingly, the friction coefficient f_3 . Then the second part m_2 , the proportion of the soil - with the angle of friction on the steel φ_1 and, respectively, the friction coefficient f_1 .

There are two possible case studies.

Case 1. The friction angle of the plant remains or the plant root on the metal φ_3 and, accordingly, the friction coefficient f_3 , bigger than the friction angle of the soil on the metal φ_1 .

Then $\varphi_3 > \varphi_1$ and $f_3 > f_1$, which leads to an excess of frictional force of the weed on a steel over the friction force of the ground on the steel. At the same time, the force of the dynamic pressure will influence on the weeds, determined by the formula (20). In this case, the force of the dynamic push D_{t1} must be higher than the strength of the soil friction on the steel $D_{t1} \geq T_3$. Therefore, to ensure weed movement, condition (22) should look like:

$$\gamma_1 \leq \arctg\left(\sqrt{\frac{1}{f_{3max}}}\right) \tag{23}$$

where f_{3max} - maximum friction coefficient of weeds on metal.

Case 2. The angle of weed friction on metal φ_3 and, accordingly, the friction coefficient f_3 is smaller than the friction angle of the soil on the metal φ_1 . In this case, $\varphi_3 < \varphi_1$ and $f_3 < f_1$ and, accordingly, the soil friction strength on the steel exceeds the friction force of the plant remain on the steel $T_1 > T_3$. Such values of the friction angles lead to the fact that the force of the dynamic push will perceive the proportion of the soil, while $D_{t1} \geq T_1$. In this case, the condition that ensures the movement of the weed and the soil, should look like:

$$\gamma_1 \leq \arctg\left(\sqrt{\frac{1}{f_{1max}}}\right) \tag{24}$$

where f_{1max} - the maximum friction coefficient of the soil on the metal.

For a general-purpose cultivator sweep it is necessary to take friction coefficient with highest meaning.

Defining the angle γ_0 by the expression

$$\gamma_0 = \gamma_1 - 7^\circ \tag{25}$$

find the inclination angle of the guide.

The values of the friction angles of the soil on steel are presented in Table. 1

Table 1

The boundaries of changing the friction angle of the soil on the steel

Soil texture	The friction angle of the soil on a steel, φ_1 [degree]	The coefficient of soil friction on a steel, f_1
Sandy	26°30'...35°	0,499...0,7
Light and medium loam	19°30'...26°30'	0,354...0,499
Heavy loam and clay	31°...42°	0,601...0,9

Heavy loam and clay have the largest angle of friction $\varphi_1 = 42^\circ$. The maximum friction angle of the plant roots on the steel is $\varphi_3 = 44^\circ 40'$. The values of the inclination angles are determined based on the data given and in accordance with formula (25).

The results are shown in Table. 2. As it can be seen from Table 2, the minimum inclination angle of the guide is 27° , which was taken into account when designing the sweep construction.

The experimental samples of the sweeps installed KPS-4, which were aggregated with a tractor DT-75M, are shown in fig. 4.

Table 2

The variation range of the inclination angle of the generatrix depending on the soil texture

Soil texture	The friction angle of the soil on a steel, φ_1 [degree]	Maximum friction angle of crop residues on steel, φ_3 [degree]	Inclination angle of generatrix γ_0 , [degree]
Sandy	26°30' ... 35°	37°	27°
Light and medium loam	19°30' ... 26°30'	37°	27°
Heavy loam and clay	31° ... 42°	37°	31°



Fig. 4 - Experimental samples of sweeps

Conditions of conducting experiments: speed up to 2.3 m / s, soil – ordinary molisol, soil texture – medium loam, relief - smooth, microrelief - levelled, background on the field - remains of corn stalks with length from 4 ... 7 cm to 24 cm, in quantities from 1-2 to 3-6 p / m². The soil moisture is 19.1% and the hardness of the soil is 529 kPa.

CONCLUSIONS

1. A geometric model and substantiated parameters of the surface of the cultivator sweep, equipped with elements of local strengthening, have been developed.
2. The method of designing the surface of the cultivator sweep, including the formation of the guide curve, the construction of the frame surface, the determination of horizontal, frontal, profile sections and the construction of the scan, has been developed.
3. The following limits for changing the parameters of the cultivator sweep with local reinforcement elements are determined: the width of the capture $b = 230, 270, 330$ mm; radius of sweep point $r = 20...40$ mm; angle of deflection of wings $2\gamma = 70...73^\circ$; angle of deflection $\alpha = 27...30^\circ$; angle of application of reinforcement elements to the blade $\varepsilon = 20 \dots 30^\circ$; step of reinforcing elements along the blade $h_e = 30...40$ mm; reinforcement elements length $l_e = 40...50$ mm; reinforcement elements overlap $\Delta_a = 10...15$ mm; reinforcement elements width $S_e = 3...5$ mm; reinforcement elements thickness $s = 1...2$ mm.

ACKNOWLEDGEMENT

The work has been funded by the Ukrainian Ministry of Education and Science.

REFERENCES

- [1] Badegaonkar U.R., Dixit G. Pathak K.K., (2010), An experimental investigation of cultivator shank shape on draft requirement. *Archives of Applied Science Research*, 2 (6) pp.246-255;
- [2] Biswas, H.S., (1993), Performance Evaluation and optimization of straight blades for shallow tillage and weeding in black soils, *Agric. Mech. in Asia, Africa and Latin America*, 24(4) pp.19-22;
- [3] Dewangan A., Singh Rajput N., (2017), Stress Analysis of Cultivator: A Survey Approach. Crop cultivation. *International Research Journal of Engineering and Technology*. vol.04 Issue: 01. pp.692-696;
- [4] Galat U.N., Ingale A.N., (2016), Failure Investigation & Analysis of Agricultural 9 Tyne Cultivator Used In Various Soil Condition. *International Journal on Recent and Innovation Trends in Computing and Communication*. Volume: 4 Issue: 1, pp. 173–179;
- [5] Gheres M.I., (2014), Mathematical model for studying the influence of tillage tool geometry on energy consumption. *INMATEH – Agricultural Engineering*, vol. 42, No.1, pp.5-12;
- [6] Hanna H.M., Hartzler R.G., Erbach D. C., (2000), High-speed Cultivation and Banding for Weed Management in No-Tillage Corn, *Applied Engineering in Agriculture*, vol.16, pp.359-365;
- [7] Hanna H. M., Marley S. J., Erbach D. C., Melvin S. W., (1993), Change in soil microtopography by tillage with a sweep. *Agricultural and Biosystems Engineering*. vol. 36(2), pp.301-307;
- [8] Ivan I., Deac T., (2007), Analysis of the possibilities to increase agricultural yields in Romania, Acta Technica Napocensis Series: *Applied Mathematics and Mechanics*, vol. V, Nr. 50, pp.457-460;
- [9] Kiss G.C., Bellow D.G., (1981), An analysis of forces on cultivator sweeps and spikes. *Can. Agric. Eng.* 23. pp.77-83;
- [10] Rusu T., Păcurar I., Dîrja M., Păcurar H.M., Oroian I., Cosma S.A., Ghereș M., (2013). Effects of soil tillage systems on soil, humus and water conservation properties, *Agricultural science*, Nr.4/2013, pp.35-40;
- [11] Saxena, A.C., (2003), Status report on abrasive wear of rotavator blades” CIAE, *Bhopal*, pp.1-9;
- [12] Shafi A., Sial J., Iqbal M., Hussain K.A., (2007), Development and testing of sweep shovels in field. *Pak. Journal of Agricultural Science*, vol. 44(4), pp.684-688;
- [13] Shinde G.U., Kjaale S.R., Potekar J.M., Nadre R.G., (2011), Computer Aided Design Optimization of Flexible Cultivator. *Journal of Agricultural Machinery' Science*. 7 (1), pp.77-83;
- [14] Slowinska-Jurkiewicz A., Bryk M., Medvedev V.V., (2013), Long-term organic fertilization effect on chernozem structure. *Int. Agrophys.*, 2013, 27, pp.81-87 DOI: 10.2478/v10247-012-0071-1;
- [15] Srivastava A. K., Goering C. E., Rohrbach R. P., Buckmaster D.R., (2006), Soil tillage. Chapter 8, *Engineering Principles of Agricultural Machines*, 2nd ed., St. Joseph, Michigan: ASABE. Copyright American Society of Agricultural and Biological Engineers, pp.169-230;
- [16] Sullivan P., (2003), Principles of Sustainable Weed Management for Croplands. *ATTRA Publication #IP039*, available at: <http://attra.ncat.org/attraa-pub/PDF/weed.pdf> ;
- [17] Tutunaru L.F., Nagy E.M., Coța C., (2014), Influence of tillage tools cutting edge wear over technical and economic indicators. *INMATEH – Agricultural Engineering*, vol.44, No.3/ pp.5-12;
- [18] Vasylieva N., (2017), Economic aspects of food security in Ukrainian meat and milk clusters, *Agris Online Papers in Economics and Informatics*, vol.9, No.3, pp.81-92, ISSN 1804-1930. DOI: 10.7160/aol.2017.090308;
- [19] Vasylieva N., Velychko O., (2017), Development of the controlling system in the management of dairy clusters, *Eastern-European Journal of Enterprise Technologies*, vol. 4, No. 3 (88): Control Processes, pp. 20-26. ISSN 1729-3774 (Print), 1729-4061 (Online). DOI: 10.15587/1729-4061.2017.108591;
- [20] Wang X.M., He, X.L., (2002), Effect of Boron addition on structure and properties of low carbon bainitic steels, *ISIJ International*, 42, pp. 538-546;
- [21] Zhang J., Kushwaha R.L., (2004), Wear and draft of cultivator sweeps with hardened edges. *Canadian Agricultural Engineering*, 37 (1), pp.41- 47.