

UDC 637.521.473; 612.396.114

DOI: 10.15587/1729-4061.2023.276249

*The object of this study is a production technique of meat chopped semi-finished products with the addition of dried semi-finished product based on Jerusalem artichoke and zucchini.*

*The production technique of meat chopped semi-finished products with the addition of dried semi-finished products of a high degree of readiness (Jerusalem artichoke and zucchini) has been improved. The dried semi-finished product is manufactured by a low-temperature drying technique in an IR field at a temperature of 45...60 °C to the final solids content of 12...15 %. The adsorption properties of the dried semi-finished product of a high degree of readiness were determined and it was established that its swelling takes place due to the absorption of the water-fat emulsion while there is an actual increase in the volume of the semi-finished product by 2.3...2.6 times.*

*A feature of the production technique of meat chopped semi-finished products with the addition of a high-readiness dried semi-finished product to the recipe is frying in an apparatus with functionally closed media. The duration of frying in the proposed apparatus with functionally closed media compared to the conventional technique is reduced by 2.4 times. Introduction to the recipe of meat chopped semi-finished products of dried semi-finished products based on Jerusalem artichoke and zucchini reduces total weight loss by 11.9 % of meat culinary products without shrinkage. The data on the chemical composition of meat chopped semi-finished products with the addition of dried semi-finished products in comparison with the control confirm the increase in the nutritional value of the prototype while the energy value is reduced by 19 %. The implementation of the improved technique will make it possible to obtain a competitive range of meat chopped products with natural ingredients that increase the nutritional value of products and eliminate the use of artificial ingredients*

*Keywords: meat chopped semi-finished products, Jerusalem artichoke, zucchini, low-temperature heat treatment, functionally closed media, IR heating, adsorption dynamics*

# IMPROVING THE PRODUCTION TECHNIQUE OF MEAT CHOPPED SEMI-FINISHED PRODUCTS WITH THE ADDITION OF DRIED SEMI-FINISHED PRODUCT WITH A HIGH DEGREE OF READINESS

**Andrii Zahorulko**

*Corresponding author*

PhD, Associate Professor\*

**Aleksey Zagorulko**

PhD, Associate Professor\*

**Maryna Yancheva**

Doctor of Technical Sciences, Professor, Dean\*\*

**Oksana Savinok**

PhD, Associate Professor

Department of Animal Husbandry Products Processing and Food Technologies

Mykolayiv National Agrarian University

Georgiy Gongadze str., 9, Mykolaiv, Ukraine, 54008

**Lyudmila Yakovets**

PhD, Senior Lecturer

Department of Botany, Genetics and Plant Protection\*\*\*

**Tetiana Zhelieva**

PhD, Associate Professor

Department of Meat Technology\*\*

**Oksana Skoromna**

PhD, Associate Professor

Department of Technology of Production of Livestock Products\*\*\*

**Larysa Sushko**

Senior Lecturer, Deputy Dean for Educational Work

Department of Higher Mathematics, Physics and General Engineering Disciplines

Dnipro State Agrarian and Economic University

Sergiy Yefremov str., 25, Dnipro, Ukraine, 49600

**Alla Kainash**

PhD, Doctor of Philosophy, Associate Professor

Department of Food Production

Poltava State Agrarian University

Skovorody str., 1/3, Poltava, Ukraine, 36003

**Nataliia Tytarenko\***

\*Department of Equipment and Engineering of Processing and Food Industries\*\*

\*\*State Biotechnological University

Alchevskyykh str., 44, Kharkiv, Ukraine, 61002

E-mail: zagorulko.andrey.nikolaevich@gmail.com

\*\*\*Vinnytsia National Agrarian University

Sonyachna str., 3, Vinnytsia, Ukraine, 21008

Received date 20.01.2023

**How to Cite:** Zahorulko, A., Zagorulko, A., Yancheva, M., Savinok, O., Yakovets, L., Zhelieva, T., Skoromna, O., Sushko, L., Kainash, A., Tytarenko, N. (2023).

Accepted date 23.03.2023

Improving the production technique of meat chopped semi-finished products with the addition of dried semi-finished product with a high degree of readiness.

Published date 28.04.2023

Eastern-European Journal of Enterprise Technologies, 2 (11 (122)), 6–14. doi: <https://doi.org/10.15587/1729-4061.2023.276249>

## 1. Introduction

Rational nutrition is the key to the formation of strong immunity among consumers and increased resistance to

environmental challenges that lead to the development and manifestation of various diseases [1]. At the same time, the existing range of food products in most cases uses synthetic flavors, dyes, various stimulants, etc. in their formulations,

which in no way affect the formation of the immune component of society. One of the ways to increase the nutritional value of food and minimize artificial ingredients in recipes is the use of natural herbal ingredients, which is a source of therapeutic and prophylactic purposes [2].

The existing range of meat products such as cutlets, rolls, etc. is a component of the daily nutrition of many countries that in most cases are made according to traditional hardware and technological solutions [3]. The use of heat and mass exchange equipment for the resource-efficient process of frying meat chopped products will increase the demand for the resulting products. The production of chopped meat products without synthetic components with rationally grounded natural components obtained under gentle temperature regimes will increase the food component and "health" properties.

Rationally combining the hardware and technological component in the production of meat chopped semi-finished products will ensure the competitiveness of the products obtained due to the high-quality implementation of the technological process under the conditions of using modern resource-efficient solutions. Improving the production technique of meat chopped semi-finished products with the addition of dried semi-finished products of a high degree of readiness obtained by modern engineering and technological solutions is an urgent task of the food industry in European countries.

---

## 2. Literature review and problem statement

---

Significant interest of consumers is observed in chopped meat semi-finished products with a regulated nutrient composition due to the introduction of vegetable fillers to the recipe, ensuring the expansion of the range of combined food products, in particular culinary products and the apparatus for their manufacture [4]. But at the same time, only the heat treatment of meat delicacies was investigated and an integrated approach to the creation of low-temperature devices of this type was not substantiated. Work [5] shows the effectiveness of the use of plant materials in food formulations to give them functional properties with an increase in nutritional value and therapeutic and prophylactic action. The formation of public demand for high-quality products with a natural content of physiological nutrients in conditions of minimization of artificial ingredients and the use of natural shells is emphasized in [6], contributing to an increase in the immune component of the body. At the same time, the issue of the possible range of use of the proposed solutions in various food products has not been considered. The production of dried semi-finished products of a high degree of readiness using innovative hardware and technological solutions will ensure the competitive development of the processing and food industry under the conditions of obtaining original food products based on them. Works [7, 8] describe the hardware and technological shortcomings of equipment for the processing of plant materials (metal and energy intensity, the use of intermediate coolants, uneven temperature field, etc.), emphasizing the feasibility of using modern hardware solutions. However, the works do not contain information on ways to eliminate certain shortcomings, in particular with the use of new heat generators.

Work [9] emphasizes the relevance of a reasonable search for natural raw materials with a high content of functional

ingredients and original organoleptic properties for the formation of a health and preventive diet. The difficulty of obtaining original dried plant semi-finished products of a high degree of readiness is due to the natural properties and features of prescription technologies. For example, paper [10] presents an energy-efficient IR dryer of plant materials with an optimal cylindrical shape of the chamber to ensure uniform radiation distribution. However, the issues of the possibility of blended drying of natural raw materials in the production cycle, for example, the meat industry for use in the form of spicy-aromatic mixtures, are not considered. However, the issues of changes in the rheological behavior of minced meat when applying vegetable raw materials to provide a predictable structure of finished meat products, which is relevant in the conditions of production of health products, have not been considered. The use of Jerusalem artichoke due to the content of original ingredients with antitoxic, immunostimulating, and other properties of biologically active substances, including inulin, will make it possible to obtain preventive products for people with sugar diabetes. Thus, in [11] it is noted that the components of Jerusalem artichoke, in particular inulin, a non-convertible carbohydrate such as fructan, are natural functional dietary fiber. Due to the growing popularity of inulin and the increased awareness of its low caloric content and the health effects associated with prebiotics, consumers are increasingly conscious about the consumption of foods containing inulin. It is noted that functional foods based on meat with inulin can lead to improved digestion by reducing the risk of diseases such as constipation, irritable bowel syndrome, inflammatory bowel disease, and colorectal cancer. Inulin can be an interesting prebiotic ingredient in healthier meat formulations, in addition to being a fat substitute and dietary fiber enhancer. The combination of Jerusalem artichoke with zucchini, which are traditional low-cost plant-based plants to obtain dried semi-finished products of a high degree of readiness will allow the use of the resulting semi-finished product in the formulations of meat cut products in the form of an adsorbent. Thus, it will make it possible to absorb the fat-water emulsion during frying, reducing weight loss during the culinary processing of products.

In [12], the authors considered the device for low-temperature processing of meat raw materials. It was found that for pork the processing temperature is 53...80 °C with a duration of 5.0...8.0 hours, 65...80 °C with a duration of 4.5...6.0 hours for poultry. For tender beef – 55...80 °C with an exposure of 5.0...8.0 hrs and 58...83 °C with a duration of 5.0...10.0 hours for solid beef. However, the paper does not present how the introduced vegetable raw materials affect the nutritional value of the product and the change in the adsorption properties of meat raw materials, emphasizing the relevance of research in this direction. So, for example, in [13], the need to produce a healthy diet with an automatic system for assessing the quality obtained, taking into account both consumer needs and organoleptic properties of the product, is given. However, in the context of consumption of meat chopped products, it is not fully possible to use this procedure since a certain proportion of the population does not eat meat, etc. This, in turn, requires the development of an innovative evaluation system while ensuring the high quality of the meat products obtained on modern technological equipment, focusing on the feasibility of research in this direction. For example, work [4] focuses on the relevance of the production of meat products with

original taste properties based on improved techniques of processing meat raw materials in modern hardware and technological solutions. To do this, it is proposed to use the device for low-temperature processing of meat products with IR radiation based on a film-like resistive electric heater of the emitting type with a uniform distribution of the heat flow. The device provides gentle low-temperature heat treatment but is intended for a certain category of meat delicacies and for the expansion of competitive chopped products there is a need for further research in the development of rational devices. For example, work [14] investigated heat and mass transfer and changes in the physical properties of pork during deep-frying. Sunflower oil frying was carried out within 90...110 °C, while the coefficient of moisture diffusion varied from 1.5 to 30.2·10<sup>-9</sup> m<sup>2</sup>/s, and the coefficient of convective heat transfer – from 187.7 to 226.1 W/m<sup>2</sup>·°C. It is noted that the density, color, and texture of the crust were influenced by the roasting temperature, but the study did not take into account the influence of the surface property for frying, predetermining the relevance of research in this direction. In [15], the authors investigated heat and mass transfer during frying chopped minced meat products under conditions of direct contact of the product with hot stoves with aging for 4 minutes. Measurements of changes in the temperature of the product and the heating surface during the frying period were performed. Heat flux as a function of time depended on the physicochemical properties of the roasted product and the temperature of the heating surface. However, the work does not take into account the method of heat supply, and therefore ensuring a uniform thermal field and heating the product from the contact surface to its center during frying, necessitating an intermediate operation for “turning”. Ensuring uniform heating of the product without an artificial intermediate operation to turn the product, in particular in closed functional environments (FCE), which will also reduce weight loss during frying, compared with the process in an open environment [16].

Work [17] presents modern technologies, such as high hydrostatic pressure processing and preparation using the “sous-vide” method, in particular, an assessment was carried out to improve the quality of veal cutlets. The influence on the physicochemical characteristics of veal, vegetable, and hybrid cutlets was investigated. Samples of different compositions were exposed to three pressures (350...600 MPa) for 5...15 min from “sous-vide” (55...65 °C for 15 min). The color of plant-based cakes and processed hybrids tended to have a less reddish tint and corresponded more to the yellow hue. Cutlets in color and texture parameters were similar to veal cutlets, while the physicochemical parameters of plant-based cutlets differed from veal cutlets. In particular, work [18] provides data on reducing the loss of meat cut products during frying, provided that natural ingredients are added to the recipe. For example – oats, which are good for health and well imitate the mechanical and physico-chemical characteristics of ground beef and its use (fried chopped products for hamburgers) have high organoleptic properties. However, in full, issues remain uncertain not only with the advantages of using dried semi-finished products in meat chopped products but also with the provision of natural components of adsorption properties when using FCE. This is due to the need for experimental and practical research, taking into account the type of plant material, nutrient properties, and determining the adsorption properties of dried components when frying in the water-fat fraction obtained during frying.

In addition, a significant role is played by ensuring uniform mixing of minced meat of chopped semi-finished products with vegetable raw materials, for uniform distribution of all ingredients. For large enterprises, in most cases, minced meat mixers are used, but if we consider small enterprises for the production of meat chopped semi-finished products with vegetable raw materials, it is possible to use small mixing machines [19].

Therefore, a study is needed that will ensure the production of competitive health-improving meat chopped semi-finished products with the addition of dried semi-finished products of a high degree of readiness. The practical implementation of innovative design and technological solutions will ensure the development of competitive equipment with a wide range of uses in the food sector and home life, as well as the production of products with original organoleptic properties. However, most thermal equipment for frying meat chopped semi-finished products have certain structural and technological disadvantages associated with uneven heat supply, complexity of heat treatment control, and low resource efficiency. Frying products in the environment also leads to significant losses of mass and quality, not to mention the use of secondary energy and ensuring resource efficiency. Important tasks in improving the production technique of meat chopped semi-finished products with the addition of dried semi-finished products of a high degree of readiness are the use of modern innovative solutions. In particular: ensuring the uniformity of the heat flow, preserving the natural organoleptic properties at the production stages, taking into account the adsorption properties as a factor in the conservation of mass during frying and the use of secondary energy. All this necessitates experimental and practical research to ensure the aforementioned competitive advantages in obtaining original meat chopped semi-finished products with introduced natural “health and preventive” nutrients.

---

### 3. The aim and objectives of the study

---

The aim of this study is to improve the production technique of meat chopped semi-finished products with the addition of a dried semi-finished product of a high degree of readiness based on Jerusalem artichoke and zucchini. This will expand the range of meat chopped semi-finished products with a natural nutrient component and increase the nutritional composition of products.

To accomplish the aim, the following tasks have been set:

- to offer a technique of low-temperature processing of Jerusalem artichoke and zucchini to obtain a dried semi-finished product of a high degree of readiness with the determination of adsorption properties;
- to assess the quality of frying and chemical composition of meat chopped semi-finished products with the addition of dried plant materials obtained according to the developed technique.

---

### 4. The study materials and methods

---

The object of our study is the proposed production technique of meat chopped semi-finished products with the addition of dried semi-finished products of a high degree of readiness based on Jerusalem artichoke (Bily variety, DSTU 8046:2015) and zucchini (Aspirant variety, DSTU 318-91), which are

sources of natural nutrients. The chemical composition is given in Table 1 [20–22].

Practical-experimental research was implemented at the State Biotechnological University (Kharkiv, Ukraine).

For the production of dried semi-finished products of a high degree of readiness, the natural raw material base of the Kharkiv region was used.

Table 1

Chemical composition of components for further production of dried semi-finished product of high degree of readiness [20–22]

Physiologically functional ingredients	Raw materials (100 gr)	
	Artichoke	Zucchini
Vitamin A, µg	2.0	0.09
Vitamin B <sub>1</sub> , mg	0.07	0.03
Vitamin B <sub>2</sub> , mg	0.06	0.03
Vitamin B <sub>9</sub> , µg	18.5	14.0
Vitamin PP, mg	1.6	0.6
Vitamin C, mg	6.0	14.9
Vitamin PP, mg	1.3	0.6
Phosphorus, mg	83.0	15.0
Calcium, mg	18.0	9.0
Potassium, mg	44.0	28.0
Mono - and disaccharides, mg	3.2	4.6
Dietary fibers, g	4.5	1.5
Organic acids, g	0.1	0.15
Calorie content, kcal	65.0	22.4

Dried semi-finished product of a high degree of readiness is obtained in the conditions of resource-efficient technologies using pre-heat treatment by blanching and drying in an IR field.

The frying process was implemented on an experimental model of the apparatus for low-temperature processing of meat chopped semi-finished products, which has functionally closed media (FCE) for loading meat raw materials (Fig. 1).

The device consists of two rectangular platforms placed in a protective housing (1) with functionally closed media (3), the heating of which is realized by FIREET (4). For rapid cooling of the FCE, a serpentine liquid cooler (5) is mounted on the lower plane of rectangular platforms, which is connected to the water line through a flow meter (10), which makes it possible to determine the volume of liquid spent for cooling. The platforms are interconnected in a “box” using hinged mechanisms (2).

Measuring and control unit 8 allows real-time control over the technological process by using microcontrollers made by the company “Oven” (Kharkiv, Ukraine) with the measurement (regulation) of temperatures and mass consumption (block 14) during frying. In particular, three units were mounted to measure the temperature in FCE (11), serpentine cooler (12), and FIREET surface (13).

After supplying current (220 W) to FIREET, the process of heating the plates begins with access to a constant temperature, after which the meat semi-finished product is loaded into the FCE. The upper rectangular platform via the hinged mechanism is connected to the second rectangular surface, forming a closed working environment. Frying is carried out under conditions of conductive-infrared heat supply from FIREET. In the process of heat and mass transfer processing, the water-fat emulsion is intensively separated while creating excessive pressure in the FCE, ensuring the intensification of the frying process.

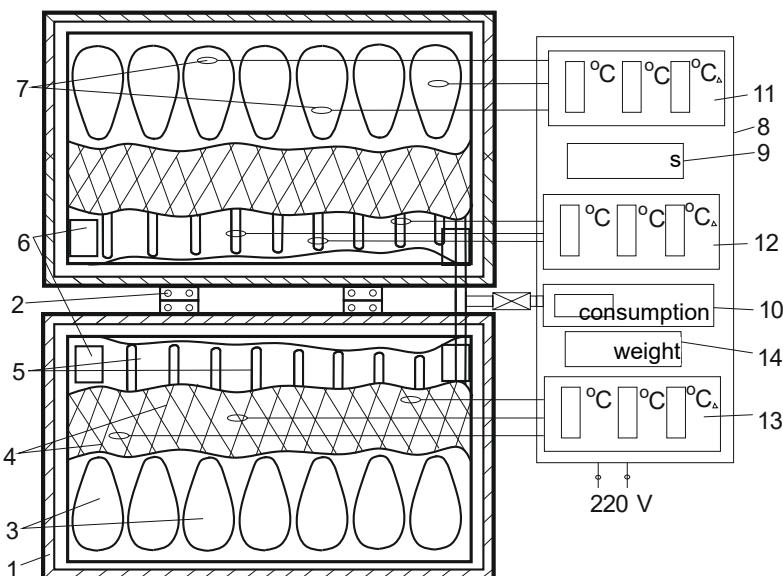

Fig. 1. Scheme of the experimental model of the apparatus for low-temperature processing of meat chopped semi-finished products with functionally closed media (in opened form): 1 – housing; 2 – hinge mechanism; 3 – functionally closed environments; 4 – film-like resistive electric heater of emitting type (FIREET); 5 – serpentine liquid cooler; 6 – Peltier elements; 7 – thermocouples; 8 – measuring and control unit; 9 – timer; 10 – meter of liquid spent on cooling the liquid; 11 – block for measuring temperature in functionally closed media; 12 – temperature measurement unit in the serpentine cooler; 13 – unit for measuring the temperature on the surface of FIREET; 14 – weight meter



Upon completion of the duration of the technological operation of frying (300 s) FIREET, the liquid supply through the flow meter to the serpentine cooler is turned off and there begins the cooling of FCE with the platforms as a whole. It also provides artificial condensation of the vapor-containing component obtained from the FCE, followed by its absorption by the chopped product.

To intensify cooling between FIREET and the serpentine cooler, Peltier elements are additionally installed, which at a temperature of heating surfaces of 170...190 °C create a temperature on the cold side of the Peltier element from -4...-6 °C. This makes it possible to reduce the temperature of the coolant from 14 °C to 9 °C without additional energy costs – actually under an autonomous mode.

The main research hypothesis assumes the possibility of improving the production technique of meat chopped semi-finished products with the addition of a dried semi-finished product of a high degree of readiness based on Jerusalem artichoke and zucchini under conditions of resource-efficient processing and implementation of hardware and technological recommendations. Thus, the expansion of the range of “health” meat chopped semi-finished products can be ensured by adding natural ingredients (inulin, vitamin C, etc.) to the recipe [23, 24].

All studies had a fivefold repeatability with a relative error of not more than 3 % using the conventional technique of processing experimental and practical data and determining chemical components.

## 5. Research on improving the production technique of meat chopped semi-finished products with the addition of dried semi-finished products

### 5.1. Low-temperature processing of Jerusalem artichoke and zucchini to obtain a dried semi-finished product of a high degree of readiness

The production of dried semi-finished products of a high degree of readiness based on Jerusalem artichoke and zucchini was carried out in accordance with the proposed technique (Fig. 2).

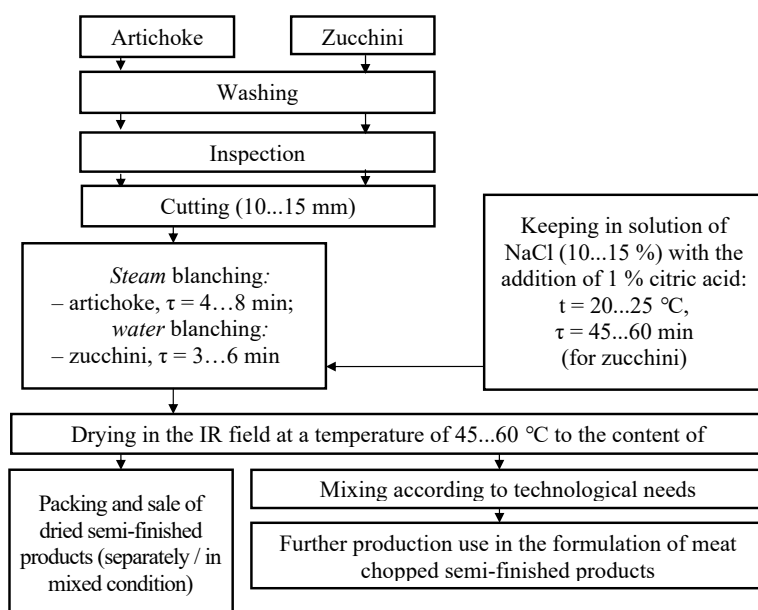

Fig. 2. Schematic diagram of the production of dried semi-finished products of a high degree of readiness based on Jerusalem artichoke and zucchini

The implementation of the technique was carried out as follows: ripe plant materials previously passed the stages of technological preparation: washing, inspection and cutting in the form of cubes with geometric dimensions of 10...15 mm. After that, the Jerusalem artichoke was pre-blanching with sharp steam at a temperature of 105...110 °C, for 4...8 min. Zucchini was blanched with water at a temperature of 85...95 °C, for 3...6 min with preliminary aging in a 10 % solution of sodium chloride (NaCl) at a temperature of 20...25 °C, for 45...60 min.

The preliminary prepared raw materials were sent for drying to a universal portable IR dryer, which can be placed directly in the production premises. Drying is implemented in the IR field at a temperature of 45...60 °C, providing resource-efficient low-temperature heat treatment with maximum preservation of natural nutrients with drying to the final content of dry matter (CP) – 12...15 %.

The obtained dried semi-finished products of a high degree of readiness in accordance with technological needs can be supplied for packaging in light-tight containers for further sale or used in accordance with technological needs, in particular in the production of semi-finished meat products.

To confirm the possibility of using the proposed dried semi-finished product of a high degree of readiness based on Jerusalem artichoke and zucchini in the formulations of various meat chopped semi-finished products, the adsorption properties of dried natural components were determined (Fig. 3).

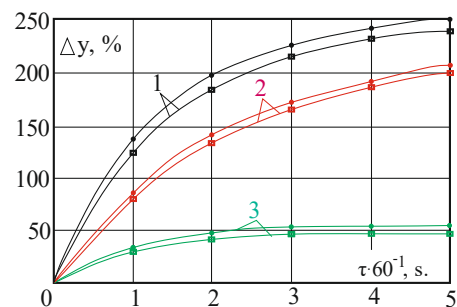

Fig. 3. Dynamics of changes in the adsorption properties of a dried semi-finished product of a high degree of readiness based on Jerusalem artichoke and zucchini when kept in a water-fat emulsion at a temperature of 80 °C and 100 °C: 1 – mass; 2 – moisture content; 3 – fat content

Physico-chemical properties of meat raw materials (minced meat) interact with dried semi-finished products in the form of meat raw materials, molten fat-containing fraction and juice-containing medium, which is formed during condensation during frying of chopped products in the FCE. The adsorption properties of dried natural components were investigated by immersion in a water-fat emulsion at a temperature close to the frying temperature of chopped products in the FCE (80 and 100 °C). At the same time, the aging process corresponded to the actual duration of the frying process in the FCE – 300 seconds, and the ratio of the components of fat:water was 1:4. This made it possible to simulate the

approximate ratio of molten fat and free moisture in the middle of the experimental chopped products during frying, the ratio of water-fat emulsion and dried semi-finished products was 7.5:1.0.

In the process of studying the adsorption properties of dried natural components in the first stages, during the first 120 seconds, there is a predicted intense change in mass, which is explained by the absorption of water and fat from the water-fat emulsion. So, for the first 120 seconds, keeping dried components at an emulsion temperature of 80 °C is 198 %, and at 100 °C, respectively, 180 %. There is a change in moisture content by 145 % and 135 %, respectively, and the fat content of dried components is 48 % and 45 %, respectively. Further aging of the components gradually reduces the rate of absorption in accordance with their acquisition of an equilibrium state. Consequently, at the final stage of aging (300 seconds), at an emulsion temperature of 80 °C – 250 %, and at 100 °C – 240 %. During the duration of aging, the moisture content changes by 210 % and 200 %, respectively, and the fat content by 55 % and 49 %.

The obtained high adsorption properties of the dried semi-finished product of a high degree of readiness based on Jerusalem artichoke and zucchini are achieved due to the low moisture content of the components (12...15 %). Ensuring an increase in the concentration of sodium chloride in zucchini due to pre-aging at a temperature of 20...25 °C for 45...60 min, as well as the absence of fat-containing components. Analysis of the intensity and degree of swelling of dried semi-finished products due to the absorption of water-fat emulsion, an increase in volume is actually observed in 2.3...2.6 times. The obtained data are confirmed by the calculated equation of material balance for the adsorption process: at 80 °C, the amount of moisture absorbed by the dried semi-finished product is 2.1 kg, and for 100 °C – 1.90 kg, respectively. Fat – 0.60 kg at 80 °C and 0.55 kg, at 100 °C.

For further research, we investigated the possibility of implementing the production of meat chopped semi-finished products with the addition of a dried semi-finished product of a high degree of readiness based on Jerusalem artichoke and zucchini. A component ratio of the minced meat product, wt%, is preliminarily proposed: beef – 40 (DSTU 6030:2008); pork – 21 (DSTU 7158:2010); wheat bread – 9; water or milk – 16; dried semi-finished products of high readiness – 8; cracker flour – 6.

## 5.2. Evaluation of the quality and chemical composition of meat chopped semi-finished products with the addition of dried plant materials

To implement the production technique of meat chopped semi-finished products with the addition of a dried semi-finished product of a high degree of readiness, it is proposed to use an experimental apparatus with functionally closed media to minimize the mass loss of products. The use of a two-component composition of Jerusalem artichoke and zucchini as a dried semi-finished product will increase the nutritional value of the resulting products due to natural nutrients and improve organoleptic characteristics.

The technological process of production of meat chopped semi-finished products with the addition of dried semi-finished product of a high degree of readiness (Fig. 4) consists of the main stages of preparation of raw materials, formulation mixing, heat treatment, and sale.

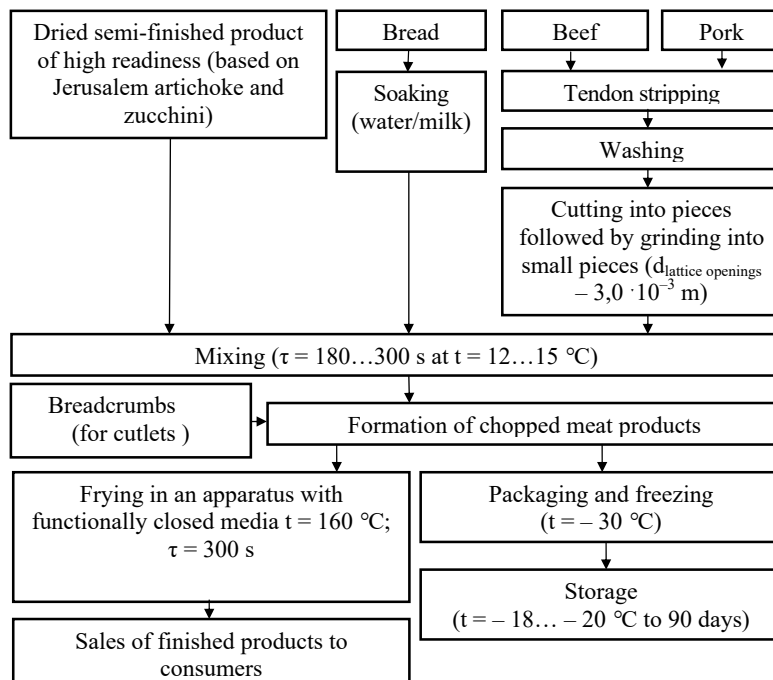

Fig. 4. Schematic technological scheme of production of chopped meat semi-finished products with the addition of dried semi-finished product of a high degree of readiness

Meat raw materials (beef and pork are pre-cleaned of tendons, washed, pre-cut into a piece-shaped fraction, and crushed in a mill to a uniform consistency ( $d_{\text{lattice openings}}=3.0 \cdot 10^{-3}$  m). After that, a technological operation is carried out to mix the crushed meat fraction with dried semi-finished product based on Jerusalem artichoke and zucchini with bread previously soaked in water or milk, salt and spices are added. Mixing process is performed for 180...300 s at a temperature of 12...15 °C followed by the formation of meat chopped products, giving them the appropriate geometric shape and mass. If necessary, breaded in breadcrumbs and fried in a machine with FCE at a temperature of 160 °C, for 300 seconds. Upon reaching culinary readiness, the device provides rapid cooling of the product with direct condensation of steam in the FCE, reducing mass losses. The process of frying meat chopped semi-finished products is accompanied by a heat and mass transfer process under the conditions of denaturation of proteins of meat raw materials with intensive removal of the juicy fraction with melting of fat and retention in the FCE. The introduction into the meat chopped semi-finished products of pre-soaked bread in water (milk) and dried semi-finished products of a high degree of readiness based on Jerusalem artichoke and zucchini ensure intensive absorption of moisture and fat during frying.

Preliminary assessment of the mass loss of meat chopped semi-finished products was performed, in accordance with the frying (shrinkage) and the duration of the frying process (Table 2), which is one of the technological indicators of the quality of frying.

**Table 2**  
Technological indicators of the quality of frying meat chopped semi-finished products

Indicator	Control	Chopped meat semi-finished product with the addition of dried semi-finished product of high readiness
Weight of semi-finished products (g)	620±20	620±20
Weight of finished products (g)	510±20	550±20
Mass loss (%)	20.4±5	11.9±5
Relative shrinkage (%)	16.0±5	–
Duration of heat treatment, s	720	300

Note: taking into account the comparison of 8 samples of meat chopped semi-finished products (control products were obtained using traditional technology)

Introduction to the recipe of meat chopped semi-finished products with the addition of dried semi-finished products of a high degree of readiness based on Jerusalem artichoke and zucchini reduces the total weight loss by 11.9 % without shrinkage of products obtained in FCE. The chemical composition of the obtained meat chopped semi-finished products with the addition of Jerusalem artichoke and zucchini in comparison with the control was determined (Table 3).

**Table 3**  
Chemical composition of chopped meat semi-finished products with the addition of dried semi-finished products of a high degree of readiness

Indicator	Meat chopped semi-finished product (control)	Chopped meat semi-finished product with the addition of dried semi-finished product of high readiness
Total moisture, %	57.6±0.1	64.4±0.1
Proteins, %	13.6±0.1	12.1±0.5
Fats, %	10.8±0.1	9.3±0.4
Carbohydrates (%) including polysaccharides:	24.3±0.2	12.1±0.5
– starch	11.9±0.1	–
– fiber	0.29±0.01	1.65±0.03
Ash, %, including:	2.3±0.01	2.7±0.01
– phosphorus (mg/100 g)	704.0±3.0	1118.0±6.0
– calcium (mg/100 g)	283.0±2.0	182.0±0.7
– iron (mg/100 g)	6.78±0.04	1.30±0.03
Fiber, %	0.2±0.01	0.23±0.01
Vitamin C, mg %	–	9.3±0.3
Energy value, kJ	233.0±3	188±3

The chemical composition of meat chopped semi-finished products with the addition of a dried semi-finished product of a high degree of readiness confirms the increase in the nutritional value of the prototype based on Jerusalem artichoke and zucchini. The energy value (caloric content) is reduced by 19 %, there is enrichment with nutrients, in particular polysaccharides of a non-starchy nature (inulin, fiber, etc.), ascorbic acid, calcium, iron, and others. To obtain a balanced

meat chopped semi-finished product due to natural micro and macro elements and the content of basic nutrients (proteins, fats, carbohydrates) similar to traditional products.

**6. Discussion of results of improving the production technique of meat chopped semi-finished products with the addition of dried semi-finished products**

Preliminary production of dried semi-finished product from Jerusalem artichoke and zucchini (Fig. 2) with its subsequent addition to the recipe of chopped meat semi-finished product (Fig. 4) increases the nutritional value of the product. The used vegetable raw materials are a natural source of dietary fiber, inulin, ascorbic acid, calcium, iron, etc. The proposed technique of drying the plant semi-finished product is characterized by the use of an IR field at a temperature of 45...60 °C, providing resource-efficient low-temperature heat treatment with maximum preservation of natural nutrients with drying to the final content of dry matter (DM) – 12...15 %. Low solids content (12...15 %) makes it possible to obtain high adsorption properties of dried semi-finished product of a high degree of readiness based on Jerusalem artichoke and zucchini. As a result of the analysis of the intensity and degree of swelling of dried semi-finished products due to the absorption of water-fat emulsion, an increase in volume is actually 2.3...2.6 times. The obtained data are confirmed by the calculated equation of the material balance for the adsorption process: at 80 °C, the amount of moisture absorbed by the dried semi-finished product is 2.1 kg, and for 100 °C – 1.90 kg, respectively. Fat – 0.60 kg at 80 °C and 0.55 kg, at 100 °C.

For the production of chopped meat semi-finished product, a component ratio is proposed in the formulation of minced meat, wt %: beef – 40; pork – 21; wheat bread – 9; water or milk – 16; dried semi-finished products of high readiness – 8; cracker flour – 6. A feature of the improved production technique is the implementation of the process of frying products in a device with FCE at a temperature of 160 °C, for 300 seconds. At the same time, the process of frying meat chopped semi-finished products is accompanied by a heat and mass transfer process under the conditions of denaturation of proteins of meat raw materials with intensive removal of the juicy fraction with the melting of fat with retention in FCE. Adding to the recipe of meat chopped semi-finished products of pre-soaked bread in water (milk) and dried vegetable semi-finished product of a high degree of readiness based on Jerusalem artichoke and zucchini provide intensive absorption of moisture and fat during frying.

The proposed improved production technique of meat chopped semi-finished products with the addition of a dried semi-finished product of a high degree of readiness ensures the use of local raw material base. This will make it possible to obtain a competitive range of meat chopped products with natural ingredients that increase the nutritional value of products and eliminate the use of artificial ingredients. The use of classic natural raw materials – Jerusalem artichoke and zucchini in the formulations of cut meat products will form functional and therapeutic and prophylactic products with original organoleptic properties. The difference between traditional technological and hardware analogs for frying meat products is the use of metal-intensive heating platforms and heating elements that complicate the control of temperature exposure, and therefore significantly affect

the resulting quality [25]. The use of innovative resource-efficient equipment in the production of dried semi-finished products of a high degree of readiness and directly frying machines with FCE will form the competitiveness of the proposed hardware and technological solutions.

The limitations of the study in the production of meat chopped semi-finished products with the addition of a dried semi-finished product of a high degree of readiness in practice is to take into account the physicochemical properties of natural raw materials, the peculiarities of processing the nutrient composition in compliance with daily consumption rates. Failure to comply with the proposed hardware and technological solutions for the implementation of the production technique will inevitably lead to a decrease in the competitive properties of meat products.

One of the shortcomings of the research is the lack of formed generalized data on the implementation of the technique when using other natural raw materials and the influence of changes in the structural properties of the product, depending on the volume of the applied mass of the dried semi-finished product. Further research will involve the rationalization of regime parameters depending on the type of plant materials and the peculiarities of nutrient processing for maximum preservation throughout the entire technological link of production, taking into account modern packaging technologies.

---

## 7. Conclusions

---

1. The developed production technique of dried semi-finished product of a high degree of readiness from Jerusalem artichoke and zucchini is proposed. The technique is characterized by a low-temperature drying process in an IR field at a temperature of 45...60 °C, providing resource-efficient heat treatment with maximum preservation of natural nutrients with drying to the final content of dry matter (DM) – 12...15 %. As a result of determining the adsorption properties of the dried semi-finished product, swelling was established due to the absorption of the water-fat emulsion and an increase in the volume of the semi-finished product is observed in fact by 2.3...2.6 times.

2. It was found that the introduction into the recipe of meat chopped semi-finished products of dried semi-finished product based on Jerusalem artichoke and zucchini reduces the total weight loss by 11.9 % without shrinkage of products obtained in FCE. The duration of frying in the proposed FCE has also been reduced by 2.4 times compared to the conventional technique. The obtained data on the chemical composition of meat chopped semi-finished products with the addition of dried semi-finished products in comparison with the control confirm the increase in the nutritional value of the prototype. It was found that the energy value is reduced by 19 %, there is enrichment with nutrients, in particular polysaccharides of non-starchy nature (inulin, fiber, etc.), ascorbic acid, calcium, iron, and others.

---

## Conflicts of interest

---

The authors declare that they have no conflicts of interest in relation to the current study, including financial, personal, authorship, or any other, that could affect the study and the results reported in this paper.

---

## Funding

---

The study was conducted without financial support.

---

## Data availability

---

All data are available in the main text of the manuscript.

---

## Acknowledgments

---

This study was carried out within the framework of the state budget theme No. 4-22-23 BO “Innovative technologies for the preservation and processing of plant materials into safe special-purpose products”.

---

## References

1. Galanakis, C. M., Rizou, M., Aldawoud, T. M. S., Ucak, I., Rowan, N. J. (2021). Innovations and technology disruptions in the food sector within the COVID-19 pandemic and post-lockdown era. *Trends in Food Science & Technology*, 110, 193–200. doi: <https://doi.org/10.1016/j.tifs.2021.02.002>
2. Munekata, P. E. S., Pérez-Álvarez, J. Á., Pateiro, M., Viuda-Matos, M., Fernández-López, J., Lorenzo, J. M. (2021). Satiety from healthier and functional foods. *Trends in Food Science & Technology*, 113, 397–410. doi: <https://doi.org/10.1016/j.tifs.2021.05.025>
3. Sgroi, F. (2021). Food traditions and consumer preferences for cured meats: Role of information in geographical indications. *International Journal of Gastronomy and Food Science*, 25, 100386. doi: <https://doi.org/10.1016/j.ijgfs.2021.100386>
4. Zahorulko, A., Cherevko, O., Zagorulko, A., Yancheva, M., Budnyk, N., Nakonechna, Y. et al. (2021). Design of an apparatus for low-temperature processing of meat delicacies. *Eastern-European Journal of Enterprise Technologies*, 5 (11 (113)), 6–12. doi: <https://doi.org/10.15587/1729-4061.2021.240675>
5. Pap, N., Fidelis, M., Azevedo, L., do Carmo, M. A. V., Wang, D., Mocan, A., Pereira, E. P. R. et al. (2021). Berry polyphenols and human health: evidence of antioxidant, anti-inflammatory, microbiota modulation, and cell-protecting effects. *Current Opinion in Food Science*, 42, 167–186. doi: <https://doi.org/10.1016/j.cofs.2021.06.003>
6. Onishchenko, V., Pak, A., Goralchuk, A., Shubina, L., Bolshakova, V., Inzhyants, S. et al. (2021). Devising techniques for reinforcing glued sausage casings by using different physical methods. *Eastern-European Journal of Enterprise Technologies*, 1 (11 (109)), 6–13. doi: <https://doi.org/10.15587/1729-4061.2021.224981>



7. McBey, D., Watts, D., Johnstone, A. M. (2019). Nudging, formulating new products, and the lifecycle: A qualitative assessment of the viability of three methods for reducing Scottish meat consumption for health, ethical, and environmental reasons. *Appetite*, 142, 104349. doi: <https://doi.org/10.1016/j.appet.2019.104349>
8. Altenburg, D., Spruyt, A. (2022). Predicting meat consumption from concurrent, automatic appraisals: Introducing nuance to product appraisals. *Appetite*, 170, 105847. doi: <https://doi.org/10.1016/j.appet.2021.105847>
9. Ramos-Diaz, J. M., Kantanen, K., Edelmann, J. M., Jouppila, K., Sontag-Strohm, T., Piironen, V. (2022). Functionality of oat fiber concentrate and faba bean protein concentrate in plant-based substitutes for minced meat. *Current Research in Food Science*, 5, 858–867. doi: <https://doi.org/10.1016/j.crfs.2022.04.010>
10. Cherevko, A., Kiptelaya, L., Mikhaylov, V., Zagorulko, A., Zagorulko, A. (2015). Development of energy-efficient ir dryer for plant raw materials. *Eastern-European Journal of Enterprise Technologies*, 4 (8 (76)), 36–41. doi: <https://doi.org/10.15587/1729-4061.2015.47777>
11. Hocquette, J.-F. (2023). Consumer perception of livestock production and meat consumption; an overview of the special issue “Perspectives on consumer attitudes to meat consumption.” *Meat Science*, 200, 109163. doi: <https://doi.org/10.1016/j.meatsci.2023.109163>
12. Zahorulko, A., Zagorulko, A., Yancheva, M., Serik, M., Sabadash, S., Savchenko-Pererva, M. (2019). Development of the plant for low-temperature treatment of meat products using ir-radiation. *Eastern-European Journal of Enterprise Technologies*, 1 (11 (97)), 17–22. doi: <https://doi.org/10.15587/1729-4061.2019.154950>
13. Wang, X., Fan, C., Wang, X., Feng, T., Zhang, X., Yu, J. et al. (2023). Microwave heating and conduction heating pork belly: Influence of heat transfer modes on volatile compounds and aroma attributes. *Food Bioscience*, 52, 102438. doi: <https://doi.org/10.1016/j.fbio.2023.102438>
14. Rocca-Polimèni, R., Zárate Vilet, N., Roux, S., Bailleul, J.-L., Broyart, B. (2019). Continuous measurement of contact heat flux during minced meat grilling. *Journal of Food Engineering*, 242, 163–171. doi: <https://doi.org/10.1016/j.jfoodeng.2018.08.032>
15. Alfieri, F., Rivero-Pino, F., Zakidou, P., Fernandez-Dumont, A., Roldán-Torres, R. (2023). Processes for Obtaining Plant-Based Dairy and Meat Substitutes. Reference Module in Food Science. doi: <https://doi.org/10.1016/b978-0-12-823960-5.00051-2>
16. Zahorulko, A., Zagorulko, A., Liashenko, B., Mikhaylov, V., Budnyk, N., Kainash, A. et al. (2022). Development of apparatus for frying semi-finished meat cut. *Eastern-European Journal of Enterprise Technologies*, 3 (11 (117)), 69–76. doi: <https://doi.org/10.15587/1729-4061.2022.259433>
17. Janardhanan, R., Huerta-Leidenz, N., Ibañez, F. C., Beriain, M. J. (2023). High-pressure processing and sous-vide cooking effects on physicochemical properties of meat-based, plant-based and hybrid patties. *LWT*, 173, 114273. doi: <https://doi.org/10.1016/j.lwt.2022.114273>
18. Kor, G., Icier, F. (2016). Thermal imaging during infrared final cooking of semi-processed cylindrical meat product. *Infrared Physics & Technology*, 79, 242–251. doi: <https://doi.org/10.1016/j.infrared.2016.11.002>
19. Zahorulko, A., Zagorulko, A., Kasabova, K., Liashenko, B., Postadzhiev, A., Sashnova, M. (2022). Improving a tempering machine for confectionery masses. *Eastern-European Journal of Enterprise Technologies*, 2 (11 (116)), 6–11. doi: <https://doi.org/10.15587/1729-4061.2022.254873>
20. Kasianchuk, V. D. (2013). Sukhyi produkt topinambura – efektyvnyi napivfabrykat dlia vyrobnytstva produktsiyi likuvalno-profilaktychnoho pryznachennia. *Halytskyi likarskykh visnyk Ivano-Frankivskoho natsionalnoho medychnoho universytetu*, 3, 103–105.
21. Telezhenko, L. N., Bezusov, A. T. (2004). *Biologicheski aktivnye veschestva fruktov i ovoschey i ikh sokhranenie pri pererabotke*. Odessa: «Optimum», 268.
22. Yudina, T., Nazarenko, I. (2016). Technological parameters and modes of getting mashed zucchini with specified functional and technological properties. *Pratsi TDATU*, 1 (16), 142–149. Available at: [http://elibrary.donnuet.edu.ua/84/1/Yud%D1%96na\\_article\\_23\\_02\\_2016.pdf.pdf](http://elibrary.donnuet.edu.ua/84/1/Yud%D1%96na_article_23_02_2016.pdf.pdf)
23. Afoakwah, N. A., Dong, Y., Zhao, Y., Xiong, Z., Owusu, J., Wang, Y., Zhang, J. (2015). Characterization of Jerusalem artichoke (*Helianthus tuberosus* L.) powder and its application in emulsion-type sausage. *LWT - Food Science and Technology*, 64 (1), 74–81. doi: <https://doi.org/10.1016/j.lwt.2015.05.030>
24. Zhu, Y., Guo, L., Tang, W., Yang, Q. (2020). Beneficial effects of Jerusalem artichoke powder and olive oil as animal fat replacers and natural healthy compound sources in Harbin dry sausages. *Poultry Science*, 99 (12), 7147–7158. doi: <https://doi.org/10.1016/j.psj.2020.08.058>
25. Babanov, I., Mikhaylov, V., Shevchenko, A., Mikhaylova, S. (2018). Perspective of roasting method of culinary products with electro-contact heat treatment. *Food Industry*, 23, 62–66. doi: <https://doi.org/10.24263/2225-2916-2018-23-11>