

ISSN 2664-9969

TECHNOLOGY AUDIT AND PRODUCTION RESERVES



**№ 2/1 (82),
2025**



Viktor Povorotnii,
Oleksandr Yaichuk,
Nataliia Karyachenko,
Iryna Shcherbyna,
Rodion Pohrebniak,
Serhii Zdanevych,
Tetiana Kimstach,
Nina Diachenko

PERTURBATION OF THE FIRST FORM OF OSCILLATIONS OF LIQUID METALLURGICAL SLAG IN THE SLAG CAR BOWL IN TRANSIENT OPERATING MODES

The object of this research is the process of oscillation of liquid metallurgical slag in a slag bowl under the influence of acceleration. The work considers the oscillation processes in bowls used on railway and road slug cars, which differ in design and operating conditions. One of the key problems associated with the transportation of liquid slag is the dynamic instability of the melt, which leads to oscillations and splashing, which can pose a safety threat and reduce the efficiency of the transportation process. In this regard, the study of the dynamics of liquid slag in bowls of various designs is an urgent task aimed at optimizing transportation parameters and developing measures to reduce the risk of slag splashing.

Based on the results of numerical modeling, it was established that the nature of the oscillations of liquid slag in the bowl significantly depends on the magnitude of the acceleration, the type of slag and the design of the bowl. In particular, the acceleration ranges at which different oscillation modes are observed, from minor surface disturbances to intensive slag splashing, have been determined. At the same time, the differences in the nature of oscillations for different types of slag and bowl designs lie within the limits determined by their physicochemical properties and geometric parameters.

The results obtained allow to conclude that it is possible to develop measures for the operation of slag bowls, as well as their designs, in the direction of reducing the amplitude of liquid slag oscillations, which, in turn, contributes to increasing transportation safety and reducing dynamic loads on the bowl walls.

The obtained data can be used in the design of new bowl designs to optimize their shape and internal elements in order to minimize slag oscillations. In addition, the information provided can be useful for metallurgical enterprises to develop effective methods for controlling and monitoring slag stability during transportation.

Keywords: slag bowl, density, viscosity, transportation, acceleration, numerical modeling, liquid slag.

Received: 13.01.2025

Received in revised form: 08.03.2025

Accepted: 18.03.2025

Published: 03.04.2025

© The Author(s) 2025

This is an open access article

under the Creative Commons CC BY license

<https://creativecommons.org/licenses/by/4.0/>

How to cite

Povorotnii, V., Yaichuk, O., Karyachenko, N., Shcherbyna, I., Pohrebniak, R., Zdanevych, S., Kimstach, T., Diachenko, N. (2025). Perturbation of the first form of oscillations of liquid metallurgical slag in the slag car bowl in transient operating modes. *Technology Audit and Production Reserves*, 2 (1 (82)), 13–18. <https://doi.org/10.15587/2706-5448.2025.325757>

1. Introduction

Transportation of liquid slag in slag bowls is an integral part of metallurgical production. In the process of moving the bowl, significant dynamic loads arise, causing oscillations of the molten slag. The study of these oscillations is an urgent scientific and technical problem that has a number of important aspects.

Firstly, oscillations of liquid slag lead to an increase in dynamic loads on the walls and bottom of the bowl, which contributes to their accelerated wear and the occurrence of fatigue cracks. This, in turn, reduces the resource of the equipment and increases the risk of emergency situations associated with the spillage of molten material. The study of slag dynamics allows to develop methods for reducing these loads, which contributes to increasing the reliability and durability of slag equipment.

Secondly, slag oscillations can cause splashing of the melt, which is dangerous for personnel and the environment. Slag splashes can lead to burns, contamination of the working area and damage to equipment. Understanding the mechanism of splash formation and factors affecting

their intensity will allow developing measures to ensure the safety of the slag transportation process.

Thirdly, slag fluctuations in the bowl can affect the quality of the slag and the efficiency of its further processing. Intensive mixing of the melt can contribute to its cooling and change in chemical composition, which complicates its further use. Controlling fluctuations allows maintaining the required temperature and composition of the slag, which increases the efficiency of the technological process.

Fourthly, the development of accurate mathematical models of liquid slag fluctuations and their validation through experimental studies are necessary to optimize the transportation parameters and design of slag bowls. This will reduce energy consumption, minimize equipment wear and tear, and increase overall production efficiency.

Therefore, the study of liquid slag fluctuations in slag bowls during transportation is an urgent task, the solution of which is of great practical importance for the metallurgical industry. The development of methods for controlling and reducing oscillations will allow to increase the safety, reliability and efficiency of the slag transportation process, as well as to ensure its high-quality processing.

The Navier-Stokes equation is a fundamental equation in fluid and gas mechanics, which describes the motion of a viscous fluid or gas. It belongs to the partial differential equations and is a system of non-linear equations, which makes their solution very difficult in general.

Solving the Navier-Stokes equations is a difficult task, especially for three-dimensional flows. For some conditions, a solution has not been found, and the mathematical problem of the existence and smoothness of solutions to the Navier-Stokes equations for three-dimensional space remains one of the most difficult problems. These equations are widely used in computer calculations, where numerical methods such as the finite volume method and the finite element method are used, which allows obtaining approximate solutions.

Due to the complexity of the analytical description of the dynamics of liquid slag, focused studies of oscillatory processes in this area have remained limited. This is due to the nonlinear nature of the oscillations, the variable physical properties of the material (viscosity, temperature, the presence of solid inclusions) and the geometric complexity of slag bowls.

However, it is worth noting the presence of a significant body of work devoted to the study of oscillations of both homogeneous and multilayer fluids under various conditions. These studies cover a wide range of configurations, from open tanks to closed vessels, and consider different modes of oscillation excitation, providing a valuable theoretical and experimental foundation for the analysis of more complex systems, such as slag bowls.

In [1], an analytical solution for free oscillations of a liquid in a horizontal cylindrical container of finite length was published. The work represents a significant contribution to the theory of oscillations, however, the direct application of the results to a slug car is limited due to differences in the geometry and physical properties (viscosity, presence of solid inclusions) of liquid slag. Nevertheless, the presented mathematical apparatus can be adapted to develop more accurate models of slag oscillations.

A well-known work [2], where the authors investigated vibrations caused by vortices in pipes transporting a liquid in the subcritical and supercritical regimes, is known. Although this work focuses on pipes, and not on open containers, it raises an important question about the interaction of the liquid and the structure. Similar mechanisms of interaction can occur between liquid slag and the walls of a slug car, especially with sharp changes in speed or direction of movement. The analysis methods used in this article can be useful for assessing the stresses in the structure of a slug car caused by slag oscillations.

In [3], methods for visualizing fluid oscillations in a closed tank subjected to oscillations are presented. The developed methods can be adapted for experimental study of oscillations of model fluids that simulate the properties of liquid slag in laboratory conditions. Visualization of oscillations will provide valuable data for verification of numerical models and understanding of damping mechanisms. However, the difficulty of maintaining high temperatures and the aggressiveness of slag represent significant obstacles to conducting experiments with real slag.

In [4], the authors proposed a modification of the equation of motion of a pipe transporting a liquid for laminar and turbulent flow regimes. In the context of a slug car, understanding the slag motion regime and its influence on the force acting on the container walls is of crucial importance. Taking into account turbulence and slag viscosity in numerical models can significantly increase their accuracy. The approaches to fluid flow modeling presented in the paper can be adapted to modeling slag movement in a slug car.

Of considerable interest are the results of research published in [5]. The authors investigated the dynamics of free surface vortex oscillations in open stirred tanks without partitions. Although mixing is different from transportation, this work emphasizes the importance of considering the shape of the free surface and its influence on the overall fluid dynamics. The methods used to describe the free surface can be adapted to modeling the surface of liquid slag.

In [6], the authors performed a numerical analysis of the dynamics of oscillations of a two-layer fluid with a free surface. Although slag is usually not a well-defined two-layer system, this work demonstrates methods for modeling multiphase flows with the free surface in mind. It is important to note that some researchers [7] consider slag as a multilayer system due to differences in density and composition of the different phases formed during the cooling process. In slag, there may indeed be stratifications in density and composition, so methods developed for two-layer fluids can be useful for modeling these effects. Analysis of the interaction between liquid layers is especially valuable.

A well-known work [8], in which the authors developed a strategy for suppressing liquid oscillations during transportation. Although direct control of slag oscillations in a slug car may be difficult, studying methods for suppressing oscillations can lead to the development of more effective vehicle motion control strategies. The control approaches discussed in the article can be used to optimize the operating modes of a slug car to minimize slag oscillations.

The results of numerical studies of the suppression of fluid vibrations in a rectangular tank using movable partitions are presented in [9]. Although the use of partitions in a slug car is not possible due to technological limitations, this work highlights the effectiveness of active vibration suppression methods. Studying the influence of spring system parameters can provide insight into how the design of a slug car can be optimized to reduce vibrations.

In [10], the authors experimentally investigated the vibration responses of a flexible riser transporting a spiral flow in deep-sea mining. This work, although not directly related to tank vibrations, emphasizes the importance of considering the elasticity of the structure and its effect on fluid dynamics. Similar effects can occur in a slug car, especially when moving over an uneven surface. The study of the resonant frequencies of the structure and their effect on slag vibrations is an important area of research.

Despite significant progress in the field of fluid mechanics and vibration dynamics, the problem of safe transportation of liquid slag in slug cars remains relevant and requires further study.

Based on the presented critical review of the literature, it can be concluded that, despite a significant amount of research in the field of fluid dynamics, the problem of modeling vibrations of liquid slag in slug cars remains insufficiently studied. Most of the works are devoted to the analysis of vibrations of homogeneous or multilayer liquids in vessels of simple geometry and under more general operating conditions. While the methods developed in these studies can be applied to the analysis of slag dynamics, they do not take into account the specific features of this material and the conditions of its transportation.

Thus, from the point of view of the applied solution methods, the study of the dynamics of liquid slag during transportation is a standard problem of fluid mechanics, requiring the use of numerical methods that take into account viscosity, surface tension and the interaction of the liquid with the walls of the container. However, the unique characteristics of the slag make this study special. These include high temperature, variable chemical composition and the presence of solid inclusions. In addition, specific operating conditions complicate the analysis. They include unsteady motion and complex geometry of the slag bowl. Therefore, the study acquires a unique character. This requires the adaptation of existing methods and the development of new approaches to modeling and analysis of results.

The aim of this research is to obtain quantitative dependences of the parameters of the first splash (first form of oscillations) of liquid metallurgical slag in the slag bowl on the acceleration of the vehicle, the geometry of the bowl and the physicochemical properties of the slag. Achieving this goal involves analyzing the influence of these factors on the amplitude of the first splash of slag, which will allow to establish their relationship and develop empirical or mathematical models that describe this process.

The practical significance of the presented research lies in the possibility of adjusting the modes of transportation of rolling stock (for bowls on the railway) and slug cars based on the obtained dependencies. Given that the obtained patterns will allow predicting the operating conditions under which the first slag splash occurs, it will be possible to optimize the parameters of vehicle movement in order to prevent emergency situations. Thus, the research results will contribute to increasing safety at metallurgical enterprises, reducing the risks of slag spillage and minimizing potential losses.

2. Materials and Methods

The object of this research is the process of oscillation of liquid metallurgical slag in a slag bowl under the influence of acceleration.

In this study, to simulate the process of oscillation of liquid slag in a slug car bowl under conditions of unsteady motion, the physicochemical characteristics of slags formed in various metallurgical processes: blast furnace and steelmaking were used as input data. The choice of these materials is due to their wide distribution and significant volume of transported slag.

Blast furnace slag, which is a by-product of cast iron production, is characterized by a complex chemical composition, the main components of which are CaO (30–45 %), SiO₂ (30–40 %), Al₂O₃ (5–15 %) and MgO (5–15 %). The viscosity of blast furnace slag in the temperature range typical for transportation (1400–1600 °C) is approximately 0.1–1 Pa·s, and the density is about 2500–3000 kg/m³ [11].

Steelmaking slag, formed during steel production, is characterized by a higher iron content (FeO up to 20 %) and a lower SiO₂ content. Its viscosity is somewhat higher than that of blast furnace slag, and can reach 1–2 Pa·s, and the density is 3000–3500 kg/m³ [11].

Given the significant variability of the physicochemical properties of slags formed in blast furnace and steelmaking industries, for the purposes of this study, averaged values of density and viscosity characteristic of liquid slags were adopted. This approach allows to simplify mathematical modeling and obtain results that reflect the general patterns of slag dynamics during transportation. The values of physicochemical characteristics used in the modeling are presented in Table 1.

Table 1

Average values of physicochemical properties of blast furnace and steelmaking slags [11]

Slag type	Viscosity, Pa·s	Density, kg/m ³
Blast furnace slag	0.5	2500
Steel-melting slag	1.5	3500

The following parameters were adopted for modeling the movement of the slug car: the speed of movement is up to 60 km/h, which corresponds to typical conditions for transporting slag through the territory of a metallurgical enterprise. Acceleration and deceleration occurring during acceleration and deceleration of the slug car were estimated in the range of 0.5–1.5 m/s² (Fig. 1), which corresponds to moderate movement modes.

To study the effect of accelerations on the first splash of liquid metallurgical slag in the slag bowl, the free surface method was applied. This method, also known as the free surface tracking method, is a computational approach designed to model the dynamics of fluids with a clearly defined boundary, in particular, at the interface of liquid with gas.

The essence of the method is to accurately track and simulate the movement of the free surface, taking into account the forces of surface tension, gravity and external influences such as acceleration. Thanks to this, it is possible to investigate surface deformation, splash formation, fluid oscillations and other phenomena that play a key role in the occurrence of the first slag splash during transportation.

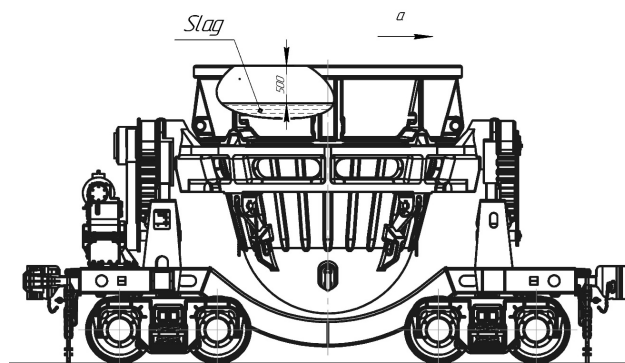

Fig. 1. Calculation scheme of a slug car with an indication of the direction of acceleration

The selected values of the physicochemical characteristics of slag and the parameters of the slug car movement are typical for real operating conditions and allow for adequate modeling of the process of oscillation of liquid slag in the bowl. The results obtained will be used to analyze the influence of various factors on the stability and safety of slag transportation, as well as to develop recommendations for optimizing the design and operating modes of slug cars.

3. Results and Discussion

Within the framework of this study, a method for numerical modeling of oscillations of liquid slag in slag bowls of various designs was developed. During the work, a slag model was placed in the virtual model of the slag bowl, the volume of which corresponded to the filling of the bowl with an underfill height of 500 mm. The physicochemical properties of slag (viscosity and density) were set according to the average values for blast furnace and steelmaking production. To simulate the transportation conditions, the bowl model was affected by acceleration, the values of which varied in the range from 0.3 m/s² to 1.2 m/s² with a step of 0.2 m/s². During the modeling process, the time of reaching the first maximum splash of liquid slag was recorded. Studies were conducted for bowl models corresponding to the designs used in road and rail transport. As a result of numerical modeling, visualizations of the dynamics of liquid slag in the bowl were obtained at different acceleration values (Fig. 2, Fig. 3). Analysis of the obtained data allowed to establish the dependence of the time of reaching the first splash (half-period of the first form of free oscillations) on the acceleration value and the type of slag. In particular, for blast furnace slag, a tendency was observed for faster occurrence of splashes compared to steelmaking slag at the same acceleration values. In addition, the design of the bowl significantly influenced the time to reach the first burst, which was manifested in a different response to the same acceleration for road and railway bowls.

The obtained visualizations (Fig. 2, Fig. 3) demonstrate the characteristic features of the movement of liquid slag in bowls of different designs at different acceleration values. In the future, it is planned to conduct a quantitative analysis of the obtained data to identify the patterns of influence of various factors on the dynamics of the oscillatory process and determine the optimal parameters of liquid slag transportation.

At first glance at the results of numerical modeling (Fig. 2, Fig. 3), one may get the impression of their similarity and general patterns in the behavior of liquid slag. Visually, with increasing acceleration, there is a tendency to increase the amplitude of the first splash in the bowl. However, a more detailed analysis of the generalized research results presented in Fig. 4 allows to identify significant differences in the dynamics of the oscillatory process.

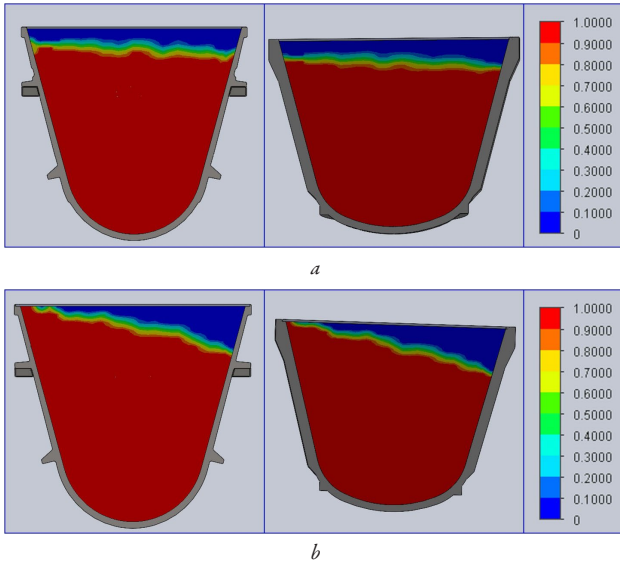

Fig. 2. Mass concentration of slag obtained during the production of cast iron and the position of the slag mirror: *a* – acceleration of the slag car on the railway track 0.3 m/s^2 ; *b* – acceleration of the slag car on the road track 1 m/s^2

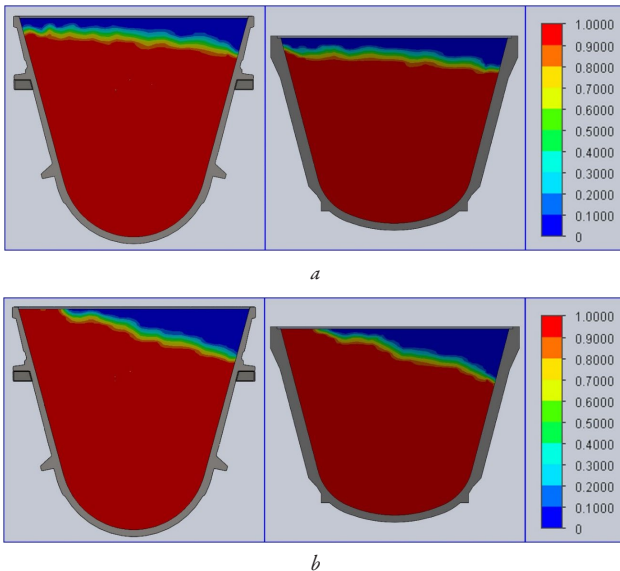

Fig. 3. Mass concentration of slag obtained during steel production and position of slag mirror: *a* – acceleration of slag car on railway track 0.3 m/s^2 ; *b* – acceleration of slag car on road track 1.2 m/s^2

Fig. 4 presents graphical dependences of the time of reaching the first splash of liquid slag on the magnitude of acceleration for different types of slag and bowl designs. From the presented data it is clear that the nature of the oscillations of blast furnace slag significantly depends on the bowl design. Blast furnace slag in the bowl on railway track (item 1) behaves more evenly. Changes in the splash time at different accelerations in this case are relatively small. However, in the bowl on road track (item 2) the dependence of the splash time on acceleration is much more pronounced. Steelmaking slags, on the contrary, demonstrate conditionally the same behavior during transportation, regardless of the bowl design.

In addition, the analysis of the graphs allows to distinguish two characteristic zones common to all studied types of slag and bowl designs. At accelerations up to 0.3 m/s^2 (zone I), slag oscillations are practically absent, and conditional ripples are formed on its surface. In zone II, at accelerations of 1 m/s^2 and more, slag splashes out of the bowl, and this pattern does not depend on the type of slag and bowl design. Thus, the

behavior of liquid slag in zones I and II is characterized by universality and does not depend on the type of slag and bowl design.

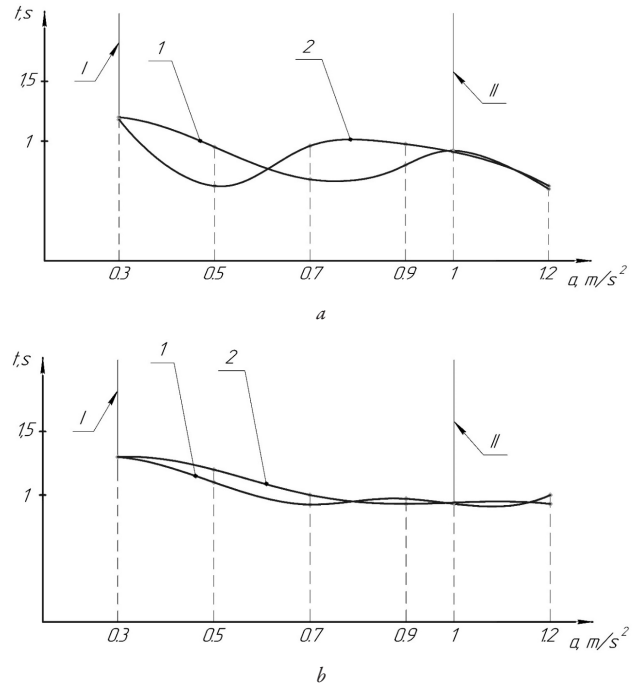

Fig. 4. Graphs of the dependence of the time of the first maximum splash on the acceleration of the slag car: *a* – results of research on bowls filled with slag after smelting of cast iron; *b* – results of research on bowls filled with slag after smelting of steel; 1 – results of research on bowls on railway tracks; 2 – results of research on bowls on road tracks; I – zone of absence of splashes and waves on the slag mirror; II – zone of guaranteed slag splash

The differences in the patterns of generalized results observed during the study of liquid slag oscillations in bowls, in our opinion, are largely due to differences in the physicochemical properties of the slag, in particular its density and viscosity. Blast furnace slag, which is characterized by a lower density and viscosity compared to steelmaking slag, demonstrates a higher susceptibility to acceleration, which is manifested in a faster achievement of the first surge. This is due to the fact that a less viscous liquid is more easily deformed and reacts faster to external influences, and a lower density contributes to an increase in the amplitude of oscillations. The influence of the bowl design on the nature of oscillations can also be associated with the density and viscosity of the slag. In particular, for blast furnace slag, which is more mobile, the shape of the bowl has a greater impact on the trajectory of the liquid and, therefore, on the time of achievement of the first surge. Steelmaking slag, which has a higher viscosity, is less sensitive to the shape of the bowl, which leads to a more uniform behavior in bowls of different designs. Thus, the differences in the patterns of generalized results observed for different types of slag and bowl designs can be explained by the complex interaction between the physical properties of the slag and the geometric characteristics of the bowl.

This study lays the foundation for a deeper and more comprehensive study of the problems of slag bowl operation, opening up new ways to optimize the processes of slag transportation and utilization in the metallurgical industry. The results obtained and the developed modeling methodology can be expanded and adapted to solve a wide range of related problems.

One of the promising directions is the study of the influence of the physical properties of the slag on the nature of oscillations in the bowl. In particular, it is necessary to study the differences in the dynamics of slags formed during the smelting of cast iron, steel and ferroalloys, taking into account their different chemical composition, viscosity and

density. An important aspect is also the study of slag oscillations during its cooling process, when there is a change in viscosity and, possibly, partial crystallization. The data obtained will allow optimizing the downtime of slag in the bowl, minimizing heat loss and the effect of temperature loads on the structure. In addition, the results of studying slag oscillations in the bowl can be used to analyze the dynamics of the movement of a slag car train, where slag oscillations act as a variable, which leads to parametric oscillations of the entire system. This aspect requires the use of complex mathematical models and numerical methods for an accurate description of the interaction of the liquid and the structure.

Also, the study of the dynamics of oscillations of liquid slag in the bowl is of particular interest in the context of the temperature problem of determining stresses in the bowl wall [12]. Considering that the temperature distribution in the bowl structure and, as a result, the thermal stresses that arise, change in time depending on the slag temperature, and the slag viscosity, in turn, is also a function of temperature, the task of finding optimal transportation modes arises. This approach will minimize dynamic loads on the bowl structure, reduce thermal stresses and, as a result, increase the service life of the equipment.

Another important direction is the assessment of the vibration process with different bowl designs, including changing the shape, size and the presence of damping elements. It is also necessary to take into account the possibility of multilayer slag, considering it as a mixture of several liquids with different densities, which can lead to the emergence of additional vibration forms and complication of dynamics [7]. It should be noted that the mechanics of liquid media is a complex and multifaceted section of mechanics, requiring an individual approach to solving each specific problem. The unique properties of slag, the design features of slag cars and operating conditions make each study in this area an important step towards improving the efficiency and safety of metallurgical production.

The limitations of this study are the use of a model slag composition instead of a real one, which can affect the absolute values of the vibration frequencies. In addition, the study was conducted in idealized laboratory conditions that do not take into account the influence of vibrations and temperature gradients characteristic of industrial furnaces. It is important to note that the model slag used had an average composition, and was not a sample from a specific smelting, which can also affect the accuracy of predicting the behavior of slag in real conditions. In addition, the influence of surface irregularities of slag transportation routes, which can significantly change the nature of oscillations, was not taken into account. For practical application of the results, it is necessary to conduct additional studies using real slag samples obtained directly from production, in conditions as close as possible to production, taking into account vibrations, temperature gradients and surface irregularities of transportation routes. It is also necessary to develop a mathematical model for scaling the obtained data to industrial scales and taking into account the variability of the slag composition.

The conduct of this study was affected by the conditions of martial law in Ukraine, which imposed certain restrictions on its implementation. In particular, access to industrial metallurgical enterprises for conducting full-fledged field studies and collecting data on real conditions of liquid slag oscillations was complicated. Security and logistical constraints have significantly reduced the opportunities for direct observation of technological processes and collection of primary data. In addition, martial law has made adjustments to the usual operating mode of scientific and educational institutions, which could affect the timing of research and the involvement of qualified specialists. In this regard, the results of the study, obtained in conditions of limited access to real production processes, require additional verification and clarification based on data obtained after the situation stabilizes and the restoration of full-fledged activity of metallurgical enterprises.

4. Conclusions

A comparative analysis of the modeling of liquid slag transportation in slag bowls of different designs, namely in bowls used in rail and road transport, was carried out.

The results of numerical modeling revealed significant differences in the nature of liquid slag oscillations in bowls of different designs. For blast furnace slag, a more pronounced dependence of the time to reach the first splash on the magnitude of the acceleration was observed in the bowl on the road than in the bowl on the railway, which indicates a greater sensitivity of blast furnace slag to the geometry of the bowl. Steelmaking slag, on the contrary, demonstrated a more uniform behavior in bowls of both designs.

Despite the differences in the nature of oscillations, a general trend was established for all studied cases: the splash after the first splash of liquid slag occurs at an acceleration of 1 m/s^2 and more. This result indicates the presence of a critical acceleration value at which active splashing of slag from the bowl begins, regardless of the type of slag and the design of the bowl. This is an important factor for developing strategies for safe transportation of liquid slag.

It was found that there are two characteristic zones (I and II) depending on the acceleration value, which significantly affect the behavior of liquid slag. In zone I, which corresponds to low acceleration values (up to 0.3 m/s^2), slag oscillations are practically absent, and a conditional ripple is formed on its surface. This is due to the fact that at low acceleration values, the inertial forces that cause oscillations are insufficient to overcome the viscous forces of slag, which effectively dampen any disturbances.

In zone II, on the contrary, at high acceleration values (1 m/s^2 and more), intensive splashing of slag from the bowl occurs. In this zone, inertial forces significantly outweigh viscous forces, which leads to the emergence of large amplitudes of oscillations of the first form and, as a result, to slag splashing. It is important to note that the boundaries of these zones, as well as the nature of the slag behavior in each of them, do not depend on the type of slag and the design of the bowl, which indicates the universality of the revealed patterns. The influence of viscosity is manifested in the fact that more viscous steelmaking slag requires greater acceleration to begin intense oscillations and splashing than less viscous blast furnace slag, but in zone II, where inertial forces dominate, this difference is leveled.

Conflict of interest

The authors declare that they have no conflict of interest regarding this study, including financial, personal, authorship or other, which could affect the study and its results presented in this article.

Financing

The study was conducted without financial support.

Data availability

The manuscript has no linked data.

Use of artificial intelligence

The authors confirm that they did not use artificial intelligence technologies in creating the presented work.

References

1. Hasheminejad, S. M., Soleimani, H. (2017). An analytical solution for free liquid sloshing in a finite-length horizontal cylindrical container filled to an arbitrary depth. *Applied Mathematical Modelling*, 48, 338–352. <https://doi.org/10.1016/j.apm.2017.03.060>

2. Dai, H. L., Wang, L., Qian, Q., Ni, Q. (2013). Vortex-induced vibrations of pipes conveying fluid in the subcritical and supercritical regimes. *Journal of Fluids and Structures*, 39, 322–334. <https://doi.org/10.1016/j.jfluidstructs.2013.02.015>
3. Disimile, P. J., Toy, N. (2019). The imaging of fluid sloshing within a closed tank undergoing oscillations. *Results in Engineering*, 2, 100014. <https://doi.org/10.1016/j.rineng.2019.100014>
4. Guo, C. Q., Zhang, C. H., Païdoussis, M. P. (2010). Modification of equation of motion of fluid-conveying pipe for laminar and turbulent flow profiles. *Journal of Fluids and Structures*, 26 (5), 793–803. <https://doi.org/10.1016/j.jfluidstructs.2010.04.005>
5. Busciglio, A., Scargiali, F., Grisafi, F., Brucato, A. (2016). Oscillation dynamics of free vortex surface in uncovered unbaffled stirred vessels. *Chemical Engineering Journal*, 285, 477–486. <https://doi.org/10.1016/j.cej.2015.10.015>
6. Cao, W., Li, X., Gao, Y., Li, X., Liu, Z. (2023). A numerical analysis of sloshing dynamics of two-layer liquid with a free surface. *Ocean Engineering*, 268, 113295. <https://doi.org/10.1016/j.oceaneng.2022.113295>
7. Chen, J., Sun, H. F., Lin, W. M., Shi, Y. L., Yi, G. L. (2012). Gravitational segregation of liquid slag in large ladle. *Metallurgija*, 195, 74844. Available at: <https://hrcak.srce.hr/74844>
8. Rothenbuchner, L., Neudorfer, C., Fallmann, M., Toth, F., Schirrer, A., Hametner, C., Jakubek, S. (2024). Efficient feedforward sloshing suppression strategy for liquid transport. *Journal of Sound and Vibration*, 590, 118542. <https://doi.org/10.1016/j.jsv.2024.118542>
9. Iranmanesh, A., Nikbakhti, R. (2021). Numerical study on suppressing liquid sloshing of a rectangular tank using moving baffles linked to a spring system. *Ocean Engineering*, 229, 109002. <https://doi.org/10.1016/j.oceaneng.2021.109002>
10. Chen, N.-Z., Zhang, J., Feng, A., Ma, Y. (2024). Experimental study on vibration responses of flexible riser transporting spiral flow in deep sea mining: Part I – Liquid single-phase transportation. *Ocean Engineering*, 298, 117068. <https://doi.org/10.1016/j.oceaneng.2024.117068>
11. Prikhodko, E. V., Togobitckaia, D. N., Khamkhotko, A. F., Stepanenko, D. A. (2013). *Prognozuvannia fiziko-khimicheskikh svoistv oksidnykh sistem*. Dnepropetrovsk: Porogi, 344.
12. Povortnii, V., Shcherbina, I., Zdanevych, S., Diachenko, N., Kimstach, T., Solonenko, L., Usenko, R. (2024). Determining the thermally-stressed state of motor-driven bowls for transporting liquid slag. *Eastern-European Journal of Enterprise Technologies*, 1 (7 (127)), 99–106. <https://doi.org/10.15587/1729-4061.2024.299180>

✉ **Viktor Povortnii**, PhD, Department of Industrial Mechanical Engineering, Ukrainian State University of Science and Technologies, Dnipro, Ukraine, e-mail: vicktorpovar@gmail.com, ORCID: <https://orcid.org/0009-0000-9128-902X>

Oleksandr Yaichuk, PhD Student, Department of Industrial Mechanical Engineering, Ukrainian State University of Science and Technologies, Dnipro, Ukraine, ORCID: <https://orcid.org/0009-0009-4034-4266>

Nataliia Karyachenko, PhD, Associate Professor, Department of Technical Mechanics, Ukrainian State University of Science and Technologies, Dnipro, Ukraine, ORCID: <https://orcid.org/0000-0002-3396-7221>

Iryna Shcherbina, PhD, Associate Professor, Department of Higher Mathematics, Physics and General Engineering Disciplines, Dnipro State Agrarian and Economic University, Dnipro, Ukraine, ORCID: <https://orcid.org/0000-0003-3968-4326>

Serhii Zdanevych, PhD, Associate Professor, Department of Higher Mathematics, Physics and General Engineering Disciplines, Dnipro State Agrarian and Economic University, Dnipro, Ukraine, ORCID: <https://orcid.org/0000-0001-8594-3806>

Rodion Pohrebniak, PhD, Associate Professor, Department of Higher Mathematics, Physics and General Engineering Disciplines, Dnipro State Agrarian and Economic University, Dnipro, Ukraine, ORCID: <https://orcid.org/0000-0002-4685-1818>

Tetiana Kimstach, PhD, Associate Professor, Department of Material Science and Heat Treatment of Metals, Ukrainian State University of Science and Technologies, Dnipro, Ukraine, ORCID: <https://orcid.org/0000-0002-8993-201X>

Nina Diachenko, Lecturer, Department of Higher Mathematics, Physics and General Engineering Disciplines, Dnipro State Agrarian and Economic University, Dnipro, Ukraine, ORCID: <https://orcid.org/0000-0002-8506-9204>

✉ Corresponding author